



BERNINA 790 PLUS

User Manual

Table of Contents

IMPORTANT SAFETY INSTRUCTIONS	9	Horizontal Spool Pin	35
Important Information	11	2.6 Feed Dog	36
1 My BERNINA	13	Adjusting the Feed Dog	36
1.1 Introduction	13	2.7 Slide-on Table	36
1.2 BERNINA Quality Control	13	Using the Slide-on Table	36
1.3 Welcome to the World of BERNINA	13	Using the Seam Guide	36
1.4 Overview Machine	15	2.8 Presser Foot	37
Overview front controls	15	Adjusting the Presser Foot Position via the Knee Lifter of the Free Hand System	37
Overview front	16	Adjusting the Presser Foot Position via the Button «Presser Foot Up/Down»	37
Overview sideways	17	Changing the presser foot	37
Overview - Back panel	18	Selecting the presser foot in the user interface	37
1.5 Supplied Accessories	18	Setting the Presser Foot Pressure	38
Overview Accessories Machine	19	2.9 Adjusting the Feed Dog	38
Overview Presser Feet	21	2.10 Needle and Stitch Plate	38
Accessory box	23	Changing the needle	38
1.6 Overview User Interface	24	Selecting the needle in the User Interface	39
Overview functions/visual information	24	Selecting needle type and needle size	39
Overview System settings	24	Adjusting the Needle Position Up/Down	40
Overview selection menu sewing	24	Adjusting the Needle Position Left/Right	40
Software Operation	25	Needle Stop Up/Down (Permanent)	40
1.7 Needle, Thread, Fabric	27	Changing the Stitch Plate	40
Overview Needles	27	Selecting the stitch plate in the User Interface	41
Example for Needle Description	30	2.11 Threading	41
Thread Selection	30	Threading the upper thread	41
Needle/Thread Combination	30	Threading the Twin Needle	44
2 Sewing Preparation	31	Threading the triple needle	44
2.1 Before Using the Machine for the First Time	31	Winding the bobbin thread	45
2.2 Accessories Box	31	Threading the Bobbin Thread	46
Accessory box free standing	31	Indicating Fill Level of Bobbin Thread	48
Storing accessory	31	3 Setup Program	49
2.3 Connection and Switching On	32	3.1 Sewing Settings	49
Connecting the Foot Control	32	Adjusting the Upper Thread Tension	49
Connecting the Machine	32	Adjusting the Maximum Sewing Speed	49
Attaching the Knee Lifter of the Free Hand System	33	Programming Securing Stitches	49
Fixing the Touch Screen Pen	33	Adjusting the hovering height of the presser foot	49
Switching the Machine On	33	Programming the button «Pattern end»	50
2.4 Foot Control	33	Programming the button «Thread cutter»	50
Regulating the Speed via the Foot Control	33	Adjusting the presser foot position with needle stop down	50
Activate/Deactivate Additional Function	34	Programming the button «Quick reverse»	51
2.5 Spool Pin	34	Programming the button «Securing»	51
Swiveling Spool Pin	34	Programming the foot control	51
		3.2 Embroidery Settings	52



Adjusting the Upper Thread Tension	52	Programming pattern repeat	65
Adjusting the Maximum Embroidering Speed	52	Programming long stitch	66
Centering or opening embroidery motifs in the original position	52	Mirror Image of Stitch Patterns	66
Calibrating the embroidery hoop	53	Edit Stitch Pattern Length	66
Entering the fabric thickness	53	Programming the Stitch Counter Function	66
Activating/Deactivating the function thread away	54	Quick Reverse	66
Programming the securing stitches	54	Permanent Quick Reverse	66
Adjusting the thread cut	54	Backstepping	67
Changing the measuring unit	55	Changing the sewing direction	67
3.3 Selecting personal settings	56	5.6 Combining stitch patterns	67
3.4 Monitoring Functions	56	Overview Combi mode	67
Activating the Upper Thread Indicator	56	Overview Combi mode extended	68
Activating the Bobbin Thread Indicator	56	Creating Stitch Pattern Combinations	68
3.5 Activating the audio signals	56	Saving a Stitch Pattern Combination	68
3.6 Machine Settings	57	Loading a Stitch Pattern Combination	68
Selecting a language	57	Overwriting a Stitch Pattern Combination	69
Adjusting the Brightness of the Display	57	Deleting a Stitch Pattern Combination	69
Adjusting the Sewing Light	57	Editing the view of the stitch pattern combination	69
Calibrating the Display	57	Editing a Single Stitch Pattern	70
Back to Basic Setting	58	Deleting a single stitch pattern	70
Deleting user data	58	Adding a Single Stitch Pattern	70
Deleting motifs on the BERNINA USB Stick	58	Relocating a single stitch pattern	71
Calibrating the Buttonhole Foot #3A	59	Adapting the Stitch Pattern length and Stitch Pattern Width	71
Packing the embroidery module	59	Mirroring a Stitch Pattern Combination	72
Reviewing the total number of stitches	59	Stitch Pattern Combination Subdivider 1	72
Registering details of the dealer	60	Stitch Pattern Combination Subdivider 2	73
Saving Service data	60	Securing a Stitch Pattern Combination	73
4 System Settings	61	Relocating several stitch patterns	73
4.1 Calling Up the Tutorial	61	Programming Pattern Repeat	73
4.2 Calling up the Creative Consultant	61	Changing the sewing direction of a stitch pattern	74
4.3 Calling up the Embroidery Consultant	61	Changing the sewing direction of a stitch pattern combination	74
4.4 Calling Up the Help	61	5.7 Administering Stitch Patterns	74
4.5 Using eco mode	61	Saving Settings of Stitch Patterns	74
4.6 Cancelling Any Alterations with «clr»	61	Calling up the previously sewn stitch patterns	74
5 Creative Sewing	62	Saving Stitch Patterns in Personal Memory	75
5.1 Overview selection menu sewing	62	Overwriting Stitch Patterns from the Personal Memory	75
Selecting a stitch pattern	62	Loading Stitch Patterns from the Personal Memory	75
5.2 BERNINA Dual Feed	62	Deleting Stitch Patterns from the Personal Memory	75
Switching on/off the BERNINA Dual Feed	63	Saving Stitch Patterns on the BERNINA USB Stick	75
5.3 Regulating the Speed	63	Uploading a Stitch Pattern from the BERNINA USB Stick	76
5.4 Adjusting the upper thread tension	64	Deleting Stitch Patterns from the BERNINA USB Stick	76
5.5 Editing Stitch Patterns	64	5.8 Stitch Designer	77
Changing the Stitch Width	64	Overview Stitch Designer	77
Changing the Stitch Length	65	Creating your own stitch pattern	77
Correcting the Balance	65	Editing the View	78
		Inserting points	78
		Relocating the points	78
		Duplicating points	78
		Deleting points	79

Activating the triple stitch	79	Sewing tapering automatically	101
Mirror image of stitch patterns	79	7.5 Sewing Cross Stitches	101
Reversing the stitch sequence	80	7.6 Pintucks	102
Designing a stitch pattern from scratch	80	Pintucks	102
Determining the stitch pattern width	80	Overview Pintuck Feet	102
5.9 Securing Stitches	80	Working with Cord	103
Securing a seam with the button «Securing»	80	Sewing Pintucks	104
Securing with the Button «Pattern End»	80	8 Alphabets and Monograms	105
5.10 Height Compensation of Uneven Layers	80	8.1 Overview Alphabets	105
5.11 Sewing Corners	81	8.2 Creating lettering	105
6 Practical Stitches	82	8.3 Altering font size	106
6.1 Overview Practical Stitches	82	8.4 Altering size of monogram	106
6.2 Sewing Straight Stitch	84	9 Buttonholes	107
6.3 Securing with the Automatic Securing Program	85	9.1 Overview Buttonholes	107
6.4 Sewing in the Zipper	85	9.2 Making Use of the Height Compensation Tool	108
6.5 Sewing Both Sides of the Zipper from Bottom to Top	86	9.3 Using the Compensation Plate	108
6.6 Sewing Triple Straight Stitch	87	9.4 Marking Buttonholes	109
6.7 Sewing Triple Zigzag	87	9.5 Cord	110
6.8 Manual Darning	88	Using Cord with the Buttonhole Foot with Slide #3A ..	110
6.9 Automatic Darning	89	Using cord with the Buttonhole Foot #3C	111
6.10 Reinforced Darning, Automatic	90	9.6 Sewing a Test Sample	112
6.11 Reinforced Darning	91	9.7 Determining the Buttonhole Slit Width	112
6.12 Finishing edges	91	9.8 Determining the Buttonhole Length with the Buttonhole Foot with Slide #3A	112
6.13 Sewing Double Overlock	92	9.9 Determining the buttonhole length with Buttonhole Foot #3C	113
6.14 Narrow Edgestitching	92	9.10 Sewing a buttonhole automatically	114
6.15 Wide Edgestitching	92	9.11 Programming the Heirloom Buttonhole	114
6.16 Edgestitching using the seam guide	93	9.12 Sewing the manual 7-step buttonhole	115
6.17 Sewing Hem Edges	93	9.13 Sewing the manual 5-step buttonhole	115
6.18 Sewing Blind Hems	94	9.14 Cutting the Buttonhole Open with the Seam Ripper	116
6.19 Sewing Visible Hems	95	9.15 Cutting Open Buttonholes with the Buttonhole Cutter (Optional Accessory)	117
6.20 Sewing Flat Joining Seams	95	9.16 Sewing on a Button	117
6.21 Sewing basting stitches	96	9.17 Sewing Eyelets	118
7 Decorative Stitches	97	10 Quilting	119
7.1 Overview Decorative Stitches	97	10.1 Overview Quilt Stitches	119
7.2 Bobbin-Play	98	10.2 Quilting, Securing Program	120
7.3 Altering the stitch density	99	10.3 Sewing handlook quilt stitches	120
7.4 Tapering	99	10.4 Guiding the Quilt Work Freely	121
Overview Tapering	99		
Altering points of a stitch pattern	100		
Sewing tapering	100		



11 BERNINA Stitch Regulator (BSR)	122	Thread-up Command	135
11.1 BSR Mode 1	122	13.5 Embroidery Hoops	135
11.2 BSR Mode 2	122	Overview Embroidery Hoop Selection	135
11.3 BSR Function with Straight Stitch No. 1	122	Selecting the Embroidery Hoop	135
11.4 BSR Function with Zigzag No. 2	122	Tear-away Stabilizers	136
11.5 Sewing Preparations for Quilting	122	Cut-away Stabilizers	136
Attach the BSR presser foot	122	Using Adhesive Spray	136
Changing the Presser Foot	123	Using Spray Starch	136
11.6 Using the BSR Mode	123	Using Iron-on Interfacing	136
11.7 Securing Stitches	124	Using Paper-backed Adhesive Stabilizer	136
Securing in BSR1 Mode with the Button «Start/Stop» ..	124	Using Water-soluble Stabilizer	137
Securing in BSR2 Mode	124	Preparing the Embroidery Hoop	137
12 My BERNINA Embroidery	125	Attaching the Hoop	138
12.1 Overview Embroidery module	125	Overview Embroidery functions	138
12.2 Supplied Accessories Embroidery Module	126	Centering the Needle to the Embroidery Hoop	138
Overview Accessory Embroidery Module	126	Move Hoop to the Back	139
12.3 Overview User Interface	127	Moving the Module for the Sewing Mode	139
Overview functions/visual information	127	Grid On/Off	139
Overview System settings	127	Locating the Center of the Embroidery Design	139
Overview Selection Menu Embroidery	127	Virtual Positioning of the Embroidery Hoop	139
12.4 Important Embroidery Information	128	14 Setup Program	141
Upper Thread	128	14.1 Adjusting the Embroidery Settings in the Setup	
Bobbin Thread	128	Program	141
Selecting the Embroidery File Format	128	15 Creative Embroidering	142
Embroidery Test	129	15.1 Overview Embroidering	142
The Size of the Embroidery Design	129	15.2 Selecting and Changing the Embroidery Design	142
Embroidering Designs by Third-party Providers	129	15.3 Checking the Embroidery Time and the Embroidery	
Underlay Stitches	129	Design Size	142
Satin or Leaf Stich	129	15.4 Regulating the Speed	142
Step Stitch	130	15.5 Editing the Embroidery Design	143
Connecting Stitches	130	Overview Editing embroidery motif	143
13 Embroidery preparation	131	Scaling Up the Embroidery Design View	143
13.1 Attaching the Module	131	Downsizing the Embroidery Design	143
13.2 Preparing the Machine	131	Moving the Embroidery Design View	143
Lowering the feed dog	131	Moving the Embroidery Design in Enlarged View	144
Selecting the embroidery motif	132	Moving the Embroidery Design	144
13.3 Embroidery Foot	132	Rotating the Embroidery Design	144
Attaching the embroidery foot	132	Altering the Embroidery Design Size Proportionally	145
Selecting the Stitch Plate in the User Interface	132	Altering the Embroidery Design Size Disproportionally	145
13.4 Needle and Stitch Plate	133	Mirroring Embroidery Designs	146
Inserting the embroidery needle	133	Changing the Stitch Type	146
Selecting the embroidery needle in the User Interface ..	133	Altering the Stitch Density	146
Selecting needle type and needle size	134	Checking the Size and the Position of the Embroidery	
Attaching the stitch plate	134	Design	147
Selecting the stitch plate in the User Interface	135	Endless Embroidery	147
		Duplicating the Embroidery Design	149
		Deleting an Embroidery Design	149
		Changing the sequence within an embroidery motif	
		combination	150

Undoing entries	150	16.2 Increasing the Embroidery Speed	166
Grouping embroidery motifs	150	16.3 Adjusting the upper thread tension	166
15.6 Pinpoint Placement	151	16.4 Embroidering via the Foot Control	167
Positioning of grid points	151	17 Care and Maintenance	168
Free point positioning	152	17.1 Firmware	168
15.7 Combining Embroidery Designs	153	Checking the firmware version	168
Combining Embroidery Designs	153	Updating firmware	168
Deleting a Single Embroidery Design	153	Recovering saved data	168
Duplicating the embroidery motif	153	17.2 Machine	169
Duplicating a combination	154	Cleaning the Display	169
15.8 Creating Lettering	154	Cleaning the Feed Dog	169
Overview embroidery alphabets	154	Cleaning the Hook	170
Creating Lettering	156	Lubricating the Hook	170
Editing the Lettering	156	Cleaning the thread catcher	172
15.9 Changing the Colors of the Embroidery Design	157	18 Errors and Faults	173
Overview changing the color	157	18.1 Error messages	173
Changing the colors	157	18.2 Troubleshooting	178
Altering the colors via the color wheel	157	19 Storage and Disposal	181
Changing the Thread Brand	158	19.1 Storing the Machine	181
15.10 Embroidering the Embroidery Design	159	19.2 Dispose of the Machine	181
Overview Embroidery menu	159	20 Technical data	182
Adding Basting Stitches	159	21 Overview Stitch Patterns	183
Moving the Hoop	159	21.1 Overview Stitch Patterns	183
Embroidery sequence control when thread breaks	159	Practical Stitches	183
Cutting Connecting Stitches	160	Buttonholes	183
Reducing Color Changes	160	Decorative Stitches	183
Multi-colored Embroidery Design On/Off	160	Quilt Stitches	187
Endless Embroidery	160	21.2 Overview Embroidery Designs	187
Color Indication	161	Editing the Embroidery Design	187
15.11 Freearm Embroidery	161	Embellishment	187
15.12 Administering Embroidery Designs	162	Quilt motifs	190
Administering Embroidery Designs	162	Borders and Lace	192
Saving Embroidery Designs in the Personal Memory	162	Children	195
Saving the Embroidery Design on the BERNINA USB Stick	163	Flowers	197
Overwriting the Embroidery Design in the Personal Memory	163	Seasons	199
Overwriting the Embroidery Design on the BERNINA USB Stick	163	Asia	201
Importing Stitch Patterns	163	Sport	202
Loading an Embroidery Design from the Personal Memory	164	Monograms in pink	204
Loading an Embroidery Design from the BERNINA USB Stick	164	Monograms in blue	206
Deleting an Embroidery Design from the Personal Memory	164	Animals	208
Deleting an Embroidery Design from the BERNINA USB Stick	164	DesignWorks	209
16 Embroidery	166	Projects	210
16.1 Embroidering via the button «Start/Stop»	166	Charming Monograms	211
		Homedeco	213
		Index	216



IMPORTANT SAFETY INSTRUCTIONS

Please be aware of the following basic safety instructions when using your machine. Before using this machine, read instruction manual carefully.

DANGER

To protect against electric shock, the following instructions must be observed.

- Never leave the machine unattended when it is connected to the power supply.
- Immediately after use and before cleaning, switch off the machine and disconnect the power cable from the outlet.

In order to protect against injury, the following instructions must be adhered to.

- Do not look directly into the LED lamp with optical instruments (e. g. magnifying glass).
- If the LED lamp is damaged or defective, have the LED lamp checked or repaired at your local authorized BERNINA dealer.
- Switch off the machine before working in the needle area.
- Before starting the machine, close all covers.

WARNING

To reduce the risk of burns, fire, electric shock or injury to persons, the following instructions must be observed.

General Facts

- This machine may only be used for the purpose described in this instruction manual.

Working Environment

- Do not use the machine outdoors.

- Only use the machine in dry rooms.
- Do not use the machine in a humid area.
- Do not use the machine in rooms where aerosol products (sprays) are being used.
- Do not use the machine in rooms where oxygen is dispensed.

Technical Condition

- Never use the machine when it is damp.
- Do not use the machine if it is not working properly.
- Do not use the machine if a cable or the plug is damaged.
- Do not use the machine if it has been dropped, damaged or has fallen into water.
- If the machine is damaged or does not work properly, have the machine checked or repaired by your local authorized BERNINA dealer.
- Keep all ventilation openings of the machine and the foot control free of lint, dust and loose cloth.
- Do not use the machine if the ventilation openings are blocked.

Accessories and Supplies

- Only use the accessories recommended by the manufacturer.
- Always use the original BERNINA Stitch Plate.
An incorrect stitch plate can result in needle breakage.
- Use only straight needles of good quality. Bent or damaged needles can cause needle breakage.
- This machine is double-insulated (except for USA, Canada and Japan). Use only identical replacement parts. See instructions for Servicing of double-insulated products.
- To lubricate the machine, only use oil recommended by BERNINA.



Safety Instructions

- While operating the machine, all protective inserts must be in place and all covers must be closed.

Appropriate Use

- The machine may be used, cleaned and maintained by children older than eight or by people with reduced physical, sensory or mental capabilities or if there is a lack of experience and knowledge as long as they have been given instructions.
- Furthermore, these persons must be supervised while working with the machine, and/or they must know the safe operation of the machine and be aware of the resulting hazards.
- Children are not allowed to play with the system.
- Special care should be taken when the machine is operated by or in the presence of children.
- Only use the machine with the supplied power cable.
- USA and Canada only: Do not connect power plug NEMA 1-15 to circuits exceeding 150 volt-to-ground.
- Only use this machine with the supplied foot control of type LV-1.
- Do not insert any objects into the openings of the machine.
- Do not place any objects on the foot control.
- While sewing, guide the fabric gently. Pulling and pushing the fabric can cause needle breakage.
- Keep fingers away from all moving parts.
- Special care is required in the needle area.
- For activities in the needle area - such as threading the needle, changing the needle, threading the looper or changing the presser foot - switch off the machine.
- To switch off, set the power switch to «0».

- When protective covers are removed, when the machine is oiled or when other cleaning and maintenance operations mentioned in this instruction manual are carried out, switch off the machine and disconnect the power plug from the outlet.
- Pull the plug out of the outlet by pulling on the plug. Do not pull on the cable.

Safety Signs on the Machine

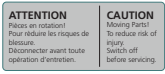
Safety signs	Purpose
	<p>Caution; moving parts.</p> <p>To reduce the risk of injury, switch off the machine before maintenance work.</p>



Important Information

Availability of the Instruction Manual

The instruction manual is supplied with the machine.



- Keep the instruction manual safe at a suitable place near the machine to have it at hand in case that you need to look up something.
- If you pass the machine to a third party, always include the instruction manual.
- The latest version of the instruction manual can be downloaded at www.bernina.com

Proper Use

Your BERNINA machine is conceived and designed for private household use. It is intended for sewing fabrics and other materials as described in this instruction manual. Any other use is not considered proper. BERNINA assumes no liability for consequences resulting from improper use.

Equipment and Scope of Delivery

Example images are used in these instructions for the purposes of illustration. The machines shown in the images and the accessories shown therefore do not always match the actual items included with your machine. The supplied accessory can vary depending on the country of delivery. You can acquire any accessories mentioned or shown that are not included in the scope of delivery as optional accessories from a specialist BERNINA dealer. Further accessories can be found at www.bernina.com.

For technical reasons and in order to improve the product, changes may be made to the equipment of the machine and the scope of delivery at any time and without prior notice.

Servicing of Double-insulated Products

In a double-insulated product two systems of insulation are provided instead of grounding. No grounding means is provided on a double-insulated product nor should a means for grounded be added to the product. Servicing a double-insulated product requires extreme care and knowledge of the system and should only be done by qualified service personnel. Replacement parts for a double-insulated product must be identical to the original parts in the product. A double insulated product is marked with the words: «Double-Insulation» or «double-insulated».

 The symbol may also be marked on the product.

Environmental Protection

BERNINA International AG is committed to environmental protection. We strive to minimize the environmental impact of our products by continuously improving product design and our technology of manufacturing.



The machine is labeled with the symbol of the crossed-out wastebin. This means that the machine should not be disposed of in household waste when it is no longer needed. Improper disposal can result in dangerous substances getting into the groundwater and thus into our food chain, damaging our health.

The machine must be returned free of charge to a nearby collection point for waste electrical and electronic equipment or to a collection point for the reuse of the machine. Information on the collection points can be obtained from your local administration. When purchasing a new machine, the dealer is obliged to take back the old machine free of charge and dispose of it properly.

If the machine contains personal data, you are responsible for deleting the data yourself before returning the machine.

Explanation of Symbols

 DANGER

Designates a danger with a high risk which can lead to serious injuries or even death unless it is avoided.

 WARNING

Designates a medium-risk hazard which can lead to serious injuries if not avoided.

 CAUTION

Designates a low-risk hazard which can lead to minor or moderate injuries if not avoided.

NOTICE

Designates a hazard which can lead to material damage if not avoided.



Tips from BERNINA **sewing experts** are found next to this symbol.

1 My BERNINA

1.1 Introduction

The purposes of your BERNINA 790 PLUS are sewing, embroidering and quilting. Delicate silk or satin fabrics as well as heavyweight linen, fleece and denim can be sewn without any problems with this machine. Numerous practical as well as decorative stitches, buttonholes and embroidery designs are at your disposal.

In addition to this instruction manual, following Help Programs are provided at any time to give you useful advice and support how to operate your BERNINA 790 PLUS.

The **Tutorial** gives information and explanations about various aspects of sewing and embroidering as well as the different stitches.

The **Creative Consultant** informs you about decision support for sewing projects. After entering the kind of fabric and the desired sewing project, suggestions concerning the suitable needle or the appropriate presser foot are displayed.

The **Embroidery Consultant** informs you about decision support for embroidery projects. After entering the desired embroidery project and the fabric, suggestions for the suitable needle and the suitable embroidery foot are displayed.

The **Help Program** provides information about individual stitch patterns, functions and operations in the user interface.

Further Information



In addition to this instruction manual for your BERNINA 790 PLUS, further informative print media are enclosed.

The current version of your manual as well as many other information about the machine and the accessories can be found on our website <https://www.bernina.com>

1.2 BERNINA Quality Control

All BERNINA machines are assembled with utmost care and are subjected to an extensive functionality test. The integrated stitch counter therefore indicates that the machine has already sewn stitches, which were performed exclusively for test purposes and quality control. The subsequent thorough cleaning does not exclude the possibility that thread remnants may still be found in the machine.

1.3 Welcome to the World of BERNINA

Made to create, this is the slogan of BERNINA. Not only with our machines do we support you in the implementation of your ideas. In addition to the offers listed below, we offer you lots of suggestions and instructions for your future projects as well as the opportunity to exchange ideas with other sewing, quilting and embroidery enthusiasts. We wish you lots of pleasure.

BERNINA YouTube channel



On YouTube we offer a wide range of how-to videos and support concerning the most important functions of our machines. You can also find detailed explanations many presser feet, meaning that your projects will be a complete success.

www.youtube.com/BerninaInternational

Available in English and German.

«inspiration» - the creative sewing magazine and online store with cutting patterns



Are you looking for ideas, sewing patterns and instructions for great sewing projects? In this case, the BERNINA magazine «inspiration» is exactly what you need. Three times a year, inspiration offers fantastic sewing and embroidery ideas. From seasonal fashion trends to trendy accessories and practical tips to original decorations for your home or cute sewing ideas for children.

The magazine is available in English, German, Dutch, and French.

In our online shop you can purchase "inspiration" as an e-magazine or as a print version, either as individual issues or as a subscription. Furthermore, there are many individual downloadable cutting patterns to discover! Why not take a look at inspiration.bernina.com and follow us on Instagram ([inspiration.sewing.magazin](https://www.instagram.com/inspiration.sewing.magazin)).

BERNINA Blog



Subtle instructions, free cutting patterns and embroidery designs as well as many new ideas: All this you can find in the weekly blog of BERNINA. Our experts give useful tips and explain step by step how you can achieve the desired result. In the community you can upload your own projects and exchange experiences and ideas with other sewing and embroidering enthusiasts.

www.bernina.com/blog

Available in English, German, Dutch and French.

BERNINA Social Media



Follow on social networks to learn more about events, thrilling projects as well as tips and tricks all about sewing, quilting and embroidering. We will keep you informed and we are looking forward to presenting you the one or the other highlight from the world of BERNINA.

www.bernina.com/social-media

BERNINA App



Download the BERNINA App from the App Store to your smartphone and enjoy direct access to all product information. The accessory organizer gives you an overview of your accessories and those you still would like to have. Furthermore, you have direct access to the customer portal, the blog and the "inspiration" online store, and you can always find an authorized specialist dealer near you. The app is available in the Apple App Store and the Google Play Store. You will find direct links at: www.bernina.com/app



1.4 Overview Machine

Overview front controls



- | | | | |
|---|------------------------|----|------------------------------|
| 1 | «Quick Reverse» | 7 | «Pattern Begin» |
| 2 | «Thread Cutter» | 8 | «Needle position Up/Down» |
| 3 | «Presser Foot Up/Down» | 9 | «Upper Multi-function Knob» |
| 4 | «Start/Stop» | 10 | «Lower Multi-function Knob» |
| 5 | «Pattern End» | 11 | «Needle Position Right/Left» |
| 6 | «Securing Stitches» | | |

Overview front



- | | | | |
|---|---|----|---------------------------------|
| 1 | Connection for Embroidery Module | 7 | Speed Control |
| 2 | Bobbin Cover | 8 | Thread Take-up Lever Cover |
| 3 | Connection for Accessory (Optional Accessory) | 9 | Thread Take-up Lever |
| 4 | Presser Foot | 10 | Fixing Screw |
| 5 | Needle Threader | 11 | Connection for Slide-on Table |
| 6 | Sewing Light | 12 | Connection for Free Hand System |

Overview sideways



- | | | | |
|---|---------------------------------------|----|-------------------------------------|
| 1 | Connection for Foot Control | 7 | Power Switch |
| 2 | PC-connection | 8 | Connection for Power Cable |
| 3 | Spool Pin | 9 | Magnetic Holder for Touchscreen Pen |
| 4 | Bobbin Unit Switch with Thread Cutter | 10 | Air Vents |
| 5 | Swiveling Spool Pin | 11 | USB Port |
| 6 | Handwheel | 12 | Feed Dog Up/Down |



Overview - Back panel



- | | | | |
|---|-------------------------------|----|--------------------------|
| 1 | Connection for Slide-on Table | 8 | Carry Handle |
| 2 | Connection for Darning Hoop | 9 | Bobbin Winder Pretension |
| 3 | BSR connection | 10 | Thread Guide |
| 4 | Connection for accessory | 11 | BDF BERNINA Dual Feed |
| 5 | Air Vents | 12 | Thread Cutter |
| 6 | Thread Guide | 13 | Feed Dog |
| 7 | Bobbin Winding Unit | 14 | Stitch Plate |

1.5 Supplied Accessories



You will find further information and application tips on the supplied and optional accessories at: <https://www.bernina.com/790-plus#!accessories>

Overview Accessories Machine





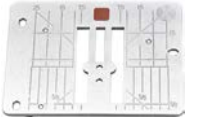















Illustration	Name	Purpose
	Dust Cover	To protect the machine from dust and contamination.
	BERNINA Accessories Box	To store the supplied accessories as well as optional accessories.
	Free Hand System (FHS)	To raise and lower the presser foot.
	Slide-On Table	To increase the sewing surface.
	Seam Guide for Slide-On Table	To support wide topstitching of edges.
	Straight and CutWork Stitch Plate	To sew straight stitches and for CutWork.
	Spool Cap	To support the regular unwinding of the thread from the spool.
	Bobbin for B9 Hook Set of 5	To wind the bobbin thread.
	Foam Pad 2 pieces	The foam pad prevents the thread from slipping, tangling or breaking on the spool pin.
	Touchscreen Pen	For precise operation of the touch screen.

Illustration	Name	Purpose
	Seam Ripper	To undo seams and to cut buttonholes open.
	Height Compensating Tool	To level an angled position of the presser foot sole when sliding over thick seams.
	Needle Assortment	For any common applications.
	Right Seam Guide	To align regular seam distances.
	Screwdriver Torx, gray	To change the needle.
	Screwdriver red (slot)	To loosen and tighten slotted screws.
	Angular Torx Wrench Torx	To open the headframe.
	Brush/Needle Inserter	To clean the feed dog and the looper area.
	Sewing Machine Oil	To oil the machine.
	Power Cable	To connect the machine with the power supply system.
	Foot Control	To start and stop the machine. To control the sewing speed.

Overview Presser Feet

Supplied Standard Presser Feet









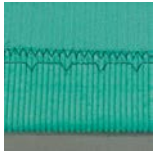

Illustration	Number	Name	Purpose	Example
	#1C	Reverse Pattern Foot	For sewing different practical and decorative stitches. To sew forward and in reverse.	
	#1D	Reverse Pattern Foot	For sewing different practical and decorative stitches. To sew forward and in reverse.	
	#2A	Overlock Foot	To finish edges in stretch material.	
	#3A	Buttonhole Foot with Slide	To sew buttonholes automatically.	
	#4D	Zipper Foot	For sewing in zippers.	
	#5	Blindstitch Foot	For sewing blind-stitch hems. For stitching edges guided on the left side of the presser foot.	
	#8D	Jeans Foot	To sew with Dual Feed. To sew denim.	

Illustration	Number	Name	Purpose	Example
	#20C	Open Embroidery Foot	For sewing applications and decorative patterns.	
	#40C	Sideways-Motion Foot	For sewing sideways motion patterns.	
	#42	BERNINA Stitch Regulator (BSR)	Free-motion quilting with regular stitch length.	



Accessory box

In the accessory box, accessories can be neatly stored in compartments and matching holders.

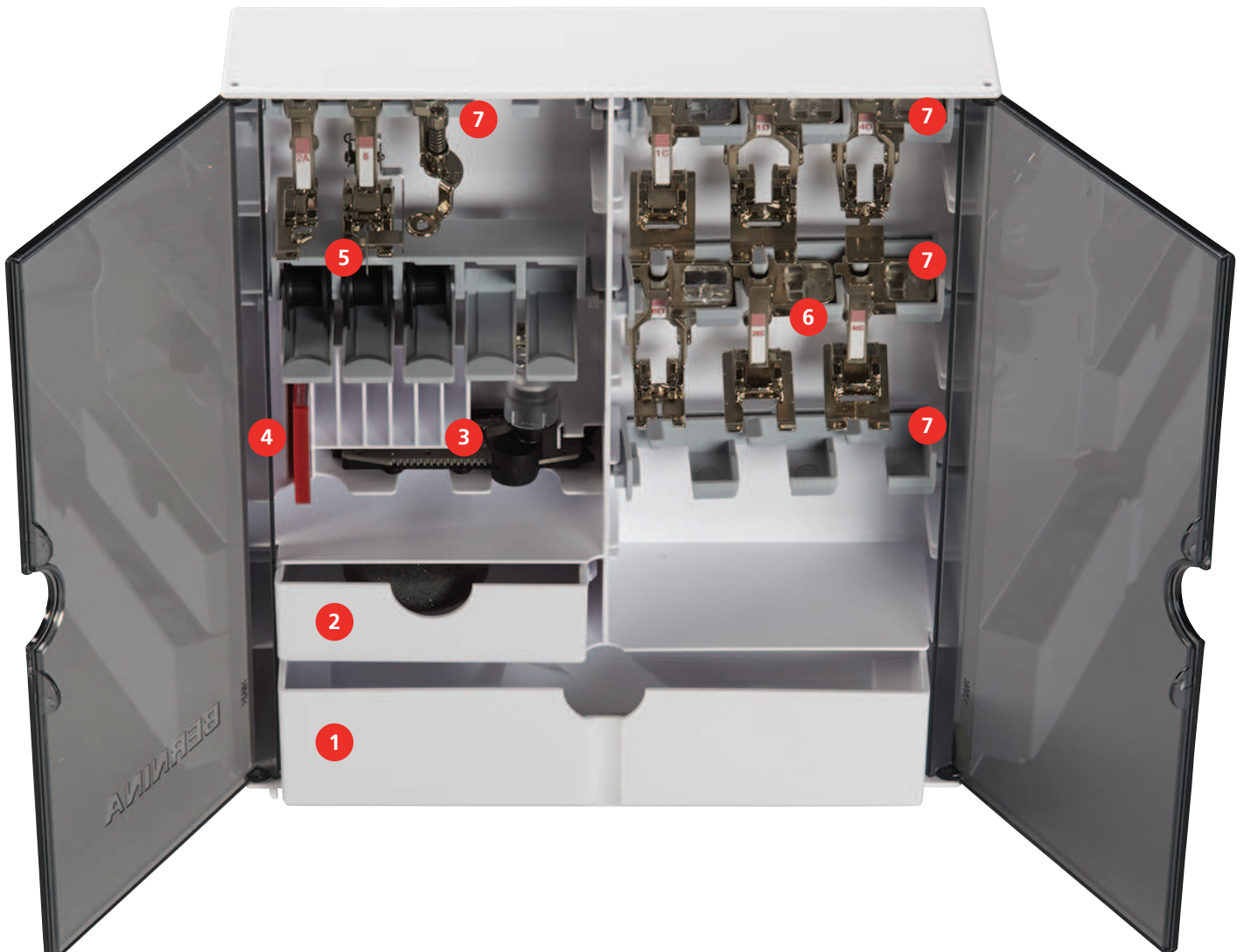

- | | | | |
|---|----------------------------|---|---|
| 1 | Big drawer | 5 | Spool Pin |
| 2 | Small drawer | 6 | Presser Feet |
| 3 | Buttonhole foot with slide | 7 | Presser Foot Holders for 5.5 mm and 9.0 mm feet |
| 4 | Selection of needles | | |

1.6 Overview User Interface

Overview functions/visual information



- | | | | |
|---|---|---|--------------------------|
| 1 | «Upper Thread Tension» | 5 | «Stitch Plate Selection» |
| 2 | «Needle Selection» | 6 | «Feed Dog Indicator» |
| 3 | «Presser Foot Indicator/Presser Foot Selection» | 7 | «Bobbin Thread» |
| 4 | «Foot Pressure» | | |

Overview System settings



- | | | | |
|---|-----------------------|---|------------------|
| 1 | «Home» | 5 | «Help» |
| 2 | «Setup Program» | 6 | «eco Mode» |
| 3 | «Tutorial» | 7 | «Clear Settings» |
| 4 | «Creative Consultant» | | |

Overview selection menu sewing



- | | | | |
|---|-----------------------|---|-------------------|
| 1 | «Practical Stitches» | 5 | «Quilt Stitches» |
| 2 | «Decorative Stitches» | 6 | «Personal Memory» |
| 3 | «Alphabets» | 7 | «History» |
| 4 | «Buttonholes» | | |

Software Operation







The touch-sensitive display can be operated with the finger or stylus.

Tap: Short tap of an element..





Swipe: Tap an element and swipe quickly on the display.

Draw: Tap the display and slowly move in one direction, eg. for scrolling up and down.

Navigation

Illustration	Name	Purpose
	«Home»	Show Home screen.
	Navigation Path	Show a previous menu level.
	«Close»	Close the window.
	More	Show more features or information.
	Continue	Scroll to next display.
	Back	Scroll to previous display.

Activate/Deactivate Functions

Illustration	Element	Status
	Switch	Function is activated.
		Function is deactivated.
	Icon	Function is deactivated.
		Function is activated.

Adjust Values

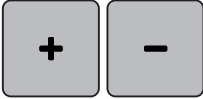
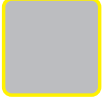

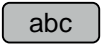

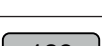

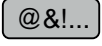

Illustration	Name	Purpose
	Slider Control	Set the value with the slider control. Reset the value to the default value by tapping the small bullet.

Illustration	Name	Purpose
	Field «Plus» / «Minus»	«Plus» increase, «Minus» reduce the value.
	Yellow Frame	Indication that the set value differs from the default value. Reset the value to the default value by tapping.

Enter Text and Numbers

To enter numerical values or text, a corresponding keyboard is shown.



Illustration	Name	Purpose
	Entry Field	Display of the entry. Delete all characters entered with a single tap.
	«Deleting»	Delete the last character.
	«Lower Case Characters»	Show the available letters in lower case letters.
	«Upper Case Characters»	Show the available letters in upper case letters.
	«Numbers and Mathematical Characters»	Show the available numbers and mathematical characters.
	«Special Characters»	Show the available special characters.
	«Confirm»	Confirm the entry and leave the submenu.
	«Cancel»	Cancel the entry and the view closes.

1.7 Needle, Thread, Fabric

Needles will wear down over time. Therefore, the needle should be replaced regularly. Only a perfect point results in a good stitching result. In general, the thinner the fabric, the finer the needle. The illustrated needles are either standard or optional accessory, depending on the machine.

- Needle sizes 70, 75: for light-weight fabrics.
- Needle sizes 80, 90: for medium fabrics.
- Needle sizes 100, 110 and 120: for heavy fabrics.

Overview Needles

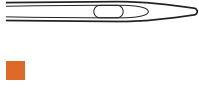

Illustration	Needle Name	Needle Description	Purpose
	Universal Needle 130/705 H 60/8 – 120/19	With a slightly rounded point.	For woven fabrics (light, medium, heavy-weight), knitwear, leather, plastic, jeans/denim. For natural and synthetic fabrics. For general sewing, sewing on buttons and buttonholes, zippers, hems and topstitching, decorative sewing, embroidery, patchwork, quilting.
	Stretch Needle 130/705 H-S 75/11 – 90/14	With a medium ball point.	For knitwear (jersey, tricot, knit and stretch material). For general sewing, sewing on buttons and buttonholes, zippers, hems and topstitching, decorative sewing, embroidery.
	Jersey/Embroidery Needle 130/705 H SUK 80/12	With a medium ball point.	For woven fabrics (light, medium, heavy-weight), knitwear, plastic. For general sewing, sewing on buttons and buttonholes, zippers, hems and topstitching, decorative sewing, embroidery.
	Jeans Needle 130/705 H-J 80/12 – 110/18	With slim, particularly acute point.	Woven fabrics (light, medium, heavy-weight), leather, jeans/denim. For general sewing, sewing on buttons and buttonholes, zippers, hems and topstitching, decorative sewing, embroidery, patchwork, quilting.
	Leather Needle 130/705 H LR 90/14, 100/16	With a cutting point (LR = special point to sew leather).	For leather, imitation leather and other similar materials. For zippers, hems and topstitching, materials that tend to stick.

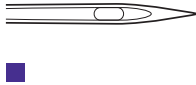
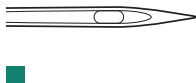
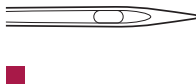
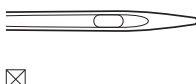
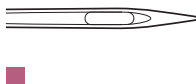
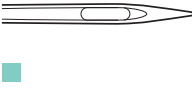

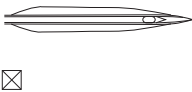
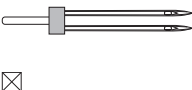

Illustration	Needle Name	Needle Description	Purpose
	Microtex Needle 130/705 H-M 60/8 – 110/18	With a particularly pointed and slender tip.	For woven fabrics (light, medium, heavy), artificial materials and materials that are difficult to work with. For silk, microfibre fabrics, foils, coated and hard-sliding materials. For sewing in general, sewing on buttons and buttonholes, zips, hems and topstitching and decorative sewing. For ultra straight stitches when topstitching edges.
	Quilting Needle 130/705 H-Q 75/11 – 90/14	With a very slim, slightly rounded point.	For woven fabrics (light, medium and heavy-weight). Decorative sewing, patchwork, quilting. For stitching/topstitching tasks, such as quilting and patchwork.
	Embroidery Needle 130/705 H-E 75/11 – 90/14	With a light ball point and a particularly wide eye and wide groove.	For woven fabrics (light, medium, heavy-weight), knitwear. For voluminous and woolen threads. For general sewing, sewing on buttons and buttonholes, zippers, hems and topstitching, decorative sewing, embroidery.
	Fine Fabrics Needle 130/705 H SES 70/10 – 90/14	With a light ball point.	For fine, delicate materials, such as velvet. For general sewing, sewing on buttons and buttonholes, zippers, hems and topstitching, decorative sewing, embroidery, patchwork, quilting.
	Metafil Needle 130/705 H METAFIL 80/12	With medium ball point and long eye (2 mm).	For woven fabrics (light, medium, heavy-weight), knitwear. For sewing with special effects and fancy threads, especially metallic threads. For embroidery with metallic thread. For hems and topstitching, decorative sewing and embroidery.

Illustration	Needle Name	Needle Description	Purpose
	Topstitch Needle 130/705 H-N 80/12 – 100/16	With medium ball point and long eye (2 mm).	For woven fabrics (light, medium and heavy-weight). For hems and topstitching, decorative sewing and embroidery. For decorative and quilting work with several sewing threads and also for embroidery.
	Felting Needle PUNCH	With small barbs.	For woven fabrics (light, medium, heavy-weight), jeans/denim. For felting a variety of yarns and threads into base fabrics.
	Hemstitch Needle 130/705 H WING 100/16, 120/20	With a «wing» on each side of the needle blade.	For woven fabrics (light, medium and heavy-weight). For special effects with hemstitch embroidery.
	Universal Twin Needle 130/705 H ZWI 70-100	Needle distance: 1.0/1.6/2.0/2.5/3.0/4.0/6.0/8.0	For visible hems in stretch fabrics, pintucks, decorative sewing.
	Stretch Twin Needle 130/705 H-S ZWI 75	Needle distance: 2.5/4.0	For visible hems in stretch fabrics, pintucks, decorative sewing.
	Hemstitch Twin Needle 130/705 H ZWIHO 100	Needle distance: 2.5	For special effects with hemstitch embroidery.
	Universal Triple Needle 130/705 H DRI 80	Needle distance: 3.0	For visible hems in stretch fabrics, decorative sewing.

Example for Needle Description

The 130/705 system, which is the most common for household machines, is explained by the following picture of a Jersey/Stretch needle.

	<p>130/705 H-S/70</p> <p>130 = Shank length (1)</p> <p>705 = Flat shank (2)</p> <p>H = Needle scarf (3)</p> <p>S = Needle point (here medium ball point) (4)</p> <p>70 = Needle size 0.7 mm (5)</p>
---	---

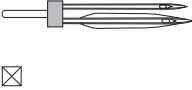
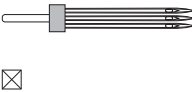
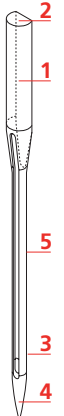

Thread Selection

For a perfect sewing result, thread and fabric quality play an important role.

We recommend purchasing quality threads to achieve good sewing results.

- Cotton threads have the advantage of being a natural fiber and therefore are especially suitable for sewing cotton fabrics.
- Mercerized cotton threads have a slight sheen that is not lost with washing.
- Polyester threads have a high tensile strength and is particularly colorfast.
- Polyester threads are more flexible and are recommended where a strong and elastic seam is required.
- Rayon threads are made of natural fibers and have a brilliant sheen.
- Rayon threads are suitable for decorative stitches and achieve a more beautiful effect.

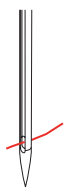
Needle/Thread Combination

	<p>The needle/thread combination is correct, when the thread fits perfectly into the long groove and goes easily through the needle eye. The thread can be optimally sewn.</p>
	<p>The thread can break and skipped stitches can occur when there is too much clearance in the long groove and the needle eye.</p>
	<p>The thread can break and get stuck when the thread scrapes against the edge of the long groove not fit well into the needle eye optimally.</p>

2 Sewing Preparation

2.1 Before Using the Machine for the First Time



BERNINA recommends lubricating the hook before using the machine for the first time or after a longer period of non-use. (see page 168)

By oiling the hook, the occurrence of unwanted noises in the hook area can be avoided.

2.2 Accessories Box

Accessory box free standing

> On the back of the box, pull both extensions out until they click into place.



Storing accessory

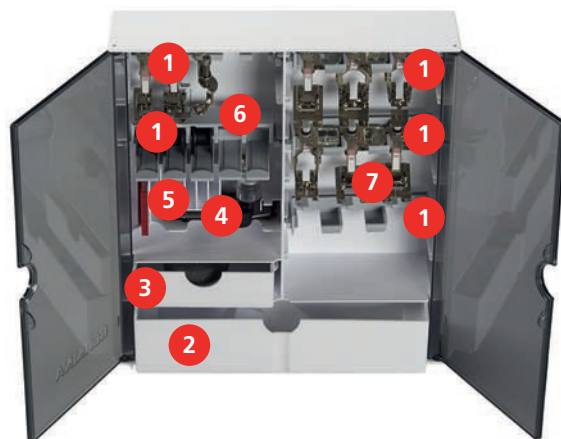

- > Insert the holders (1) for bobbins, presser feet and needles into the accessory box.
- > Store the presser feet in the holders (7) (5.5 mm or 9.0 mm).
- > Store the small parts, e.g. thread discs etc., in the drawers (2) and (3).
- > Buttonhole Foot with Slide #3A in compartment (4).
- > Store the provided needle package in the special compartment (5).

NOTICE**Scratched Sensor Surfaces of the Bobbin**

Malfunction of the lower thread indicator. If the sensor surfaces of the bobbins are scratched or dirty, the bobbin thread indicator will no longer detect the low thread level.

> Always position the bobbins in the bobbin holder with the silver sensor surface to the right.

> Position the bobbins in the bobbin holder (6) with the silver sensor surface to the right.

> To remove a bobbin, press the compartment holder down.

2.3 Connection and Switching On**Connecting the Foot Control**

The cable of the foot control is rolled up on its underside.

> Unroll the cable of the foot control to the desired length and fix it in the cable holders of the foot control.



> Insert the plug of the cable into the foot control socket of the machine.



> Place the foot control under the table.

> If the cable is too long, roll up the excess length and fix it in the cable holders of the foot control.

Connecting the Machine

To ensure safe operation of the machine, only the supplied mains cable may be used. The supplied power cable is designed for the voltage range applicable in the country of use. If the machine is to be used in a country other than the country of origin, the power cable suitable for that country must be obtained from the Authorized BERNINA dealer.

The power cable for the USA and Canada has a polarized power plug (one contact is wider than the other). To reduce the risk of an electric shock, the plug can only be inserted into the socket in one way. If the power plug does not fit in the socket, reverse then insert the power plug. If the reversed power plug still does not fit, an electrician must install an appropriate socket. Do not modify the power plug in any way.

- > Insert the device connector of the power cable into the machine's power cable connection.



- > Insert the power plug of the power cable into the socket.

Attaching the Knee Lifter of the Free Hand System



The lateral position of the lever can be adjusted by your local BERNINA Dealer required.

- > Insert the knee lifter into the opening at the front side of the machine.
- > Adjust the sitting height so that the knee lifter can be operated with the knee.

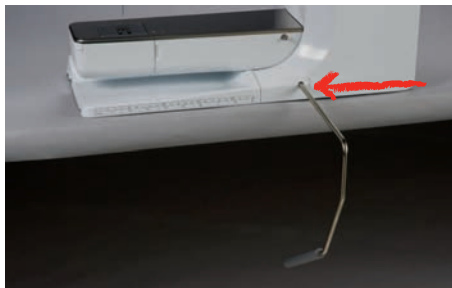

Fixing the Touch Screen Pen

- > Store the touchscreen pen at the magnet holder.



Switching the Machine On

- > Set the power switch to «I».



2.4 Foot Control

Regulating the Speed via the Foot Control

Via the foot control the speed can be adjusted infinitely variable.

- > Press the foot control down carefully to start the machine.
- > To sew faster, press the foot control harder.
- > Release the foot control to stop the machine.



Activate/Deactivate Additional Function

The Foot Control can be programmed with a second function that can be activated and deactivated by a Back-kick. On delivery, the Back-kick is programmed with the function «Needle Up/Down».

- > To raise or lower the needle, press the foot control downward with your heel.



The Back-kick function can be programmed individually. (see page 51)

2.5 Spool Pin

Swiveling Spool Pin

Installing the spool holder



With metallic or other special threads, it is recommend to use the swiveling spool pin.

The swiveling spool holder is necessary when several threads are sewn and it can also be used for bobbin winding while sewing.

- > Swivel the spool holder up as far as it will go.



Inserting foam pad and thread spool

The foam pad prevents the thread from getting hooked at the swiveling spool holder.

- > Place the foam pad on the swiveling spool holder.
- > Place the thread spool on the spool holder.



Horizontal Spool Pin

Placing the Foam Pad, the Thread Spool and the Spool Cap

Spool caps hold the thread spool in place for proper release of thread from the spool. The spool cap is only used with the horizontal spool holder.

- > Place the foam pad on the spool pin.
- > Place the thread spool on the spool pin.
- > Position the appropriate spool cap on the spool pin so that there is no space between the spool cap and the thread spool.



Using the Spool Net

The spool net holds the thread on the thread spool and prevents the thread from knotting and breaking. The spool net is only used with the horizontal spool holder.

- > Pull the spool net over the thread spool. Ensure when doing so that the spool net does not slip off the thread spool, e.g. double-insert the net over the thread spools or insert a part of the net into the thread spool at the rear.



2.6 Feed Dog

Adjusting the Feed Dog

- > To lower the feed dog, push the button «Feed Dog Up/Down».



- > To raise the feed dog, push the button «Feed Dog Up/Down» again.

2.7 Slide-on Table

Using the Slide-on Table

The Slide-on Frearm Extension Table, attached to the freearm, enables the available sewing area to be extended.

- > Raise the needle.
- > Raise the presser foot.
- > Switch off the machine.
- > Push the Slide-on Frearm Extension Table from the left to the right over the freearm until it engages.



- > To remove the Slide-on Frearm Extension Table, press the button at the table down and pull the slide-on table over the free arm to the left.



Using the Seam Guide

The seam guide for the slide-on table facilitates sewing of evenly wide edges and hems.

Prerequisite:

- The slide-on table has been fitted.
- > Touch the release button and engage the seam guide from the front to the back on the slide-on table.



- > To determine the edge width, press the release button and move the seam guide to the right or left.
- > Touch the release button and pull the seam guide away to the front.



> To display all suitable presser feet for the selected stitch pattern, tap «Optional Presser Feet».



- > Select the attached presser foot.
 - When the selected presser foot is suitable, sewing can start.
 - If the selected presser foot is not suitable for the selected stitch pattern, it can still be selected but the machine is automatically prevented from starting. An error message is displayed. If an incorrect presser foot is selected, the sewing stitch is displayed in red in the sewing stitch preview.



Setting the Presser Foot Pressure



The presser foot pressure is designed to adjust the pressure of the presser foot optimally to the fabric thickness. When working with thick fabrics, it is recommended to reduce the presser foot pressure. This provides the advantage that the fabric can be moved more easily. When the presser foot pressure is set below 0, the presser foot even lifts to give more space to the thick fabric. When working with thin fabrics, it is recommended to increase the presser foot pressure. This provides the advantage that the fabric cannot be moved too easily under the presser foot.



- > Tap «Foot Pressure».
- > Adjust the presser foot pressure.

2.9 Adjusting the Feed Dog



- > Tap «Feed Dog Indicator».
- > Raise or lower the feed dog according to the animation.

2.10 Needle and Stitch Plate

Changing the needle

- > Raise the needle.
- > Switch off the machine.
- > Remove the presser foot.

- > Loosen the Fixing Screw of the needle using the Screwdriver (Torx, gray).



- > Pull the needle down.
- > Hold the new needle with the flat side to the back.
- > Insert the needle as far as it will go.
- > Tighten the Fixing Screw with the Screwdriver.

Selecting the needle in the User Interface

After changing the needle, you can check whether this can be used with the selected stitch plate.



- > Tap «Needle Selection».
- > Select the fitted needle.

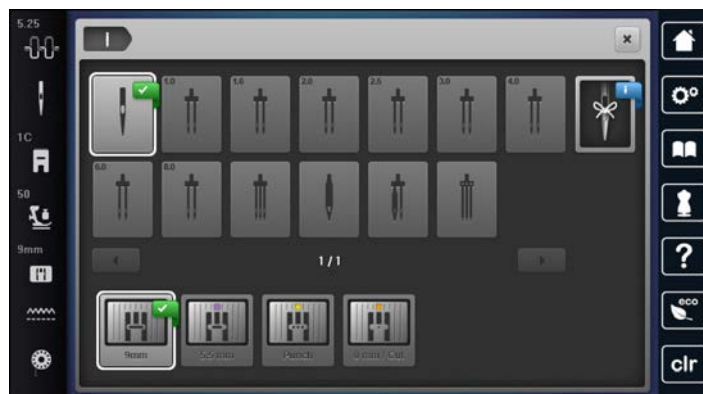

- When the selected needle matches the selected presser foot, sewing can be started. If the selected needle does not match the selected presser foot, there will be an error message when starting the machine and the machine will not sew.

Selecting needle type and needle size

Convenient memory function: To prevent a loss of information, the needle type and the needle size can be saved additionally on the machine. The saved needle type and the saved needle size can be checked at any time.



- > Tap «Needle Selection».



- > Tap «Needle Information».
- > Select the needle type (1) of the fitted needle.

- > Select the needle type (2) of the fitted needle.



Adjusting the Needle Position Up/Down



- > To lower the needle, push the button «Needle position Up/Down».
- > To raise the needle, push the button «Needle position Up/Down» again.

Adjusting the Needle Position Left/Right

There is a total of 11 needle positions. The needle position is indicated by the needle position number in the display.

- > To position the needle position to the left, push the button «Needle Position Left» (1).
- > To position the needle position to the right, push the button «Needle Position Right» (2).

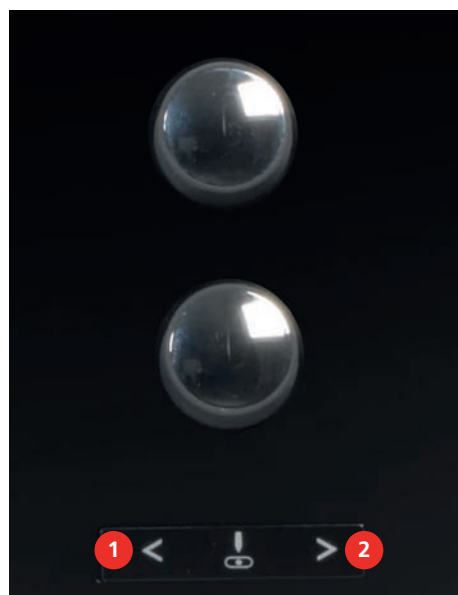

Needle Stop Up/Down (Permanent)



- > To set the needle stop position permanently, tap «Needle Stop Up/Down».
 - The machine stops with needle position down as soon as the foot control is released or the button «Start/Stop» has been pushed.
- > Tap «Needle Stop Up/Down» again.
 - The machine stops with needle position up as soon as the foot control is released or the button «Start/Stop» has been pushed.

Changing the Stitch Plate

The stitch plate is marked with vertical, horizontal and diagonal lines in millimeters (mm) and inches (inch). These markings are helpful for sewing or precise top-stitching.

Prerequisite:

- The feed dog is lowered.
 - The machine is switched off.
 - The needle and presser foot are removed.
- > At the marking on the upper right corner of the stitch plate, push the stitch plate downwards until it tips.



- > Remove the stitch plate.
- > Place the openings of the new stitch plate above the corresponding guide pins and press down until it clicks into place.

Selecting the stitch plate in the User Interface

After changing the stitch plate, you can check whether this can be used with the selected needle.



- > Tap «Stitch Plate Selection».
- > Select the previously fitted stitch plate.

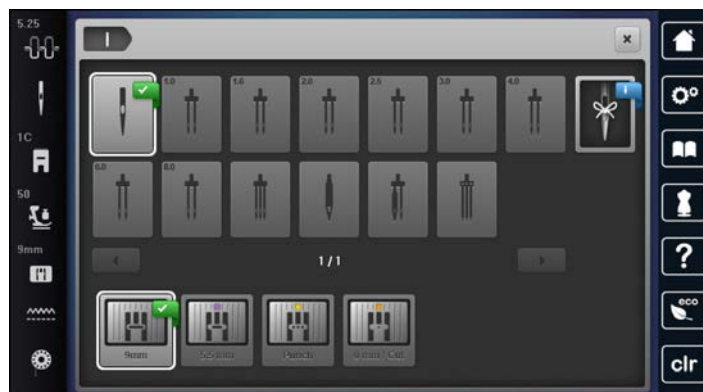

- If the selected stitch plate is suitable to be used in combination with the needle, sewing can begin.
- If the selected stitch plate is not suitable to be used in combination with the needle, an error message is displayed and starting the machine is automatically prevented.

2.11 Threading

Threading the upper thread

Prerequisite:

- The needle and the presser foot are raised.
 - The machine is switched off.
- > Place the foam pad on the spool pin.
- > Place the thread spool on the spool pin so that the thread unwinds clockwise.
- > Attach the appropriate spool cap.
- > Guide the thread in direction of the arrow through the rear thread guide (1) and hold the thread with the hands so that it is taut and can be inserted into the thread tension.

- > Guide the thread in direction of the arrow through the thread tension (2).

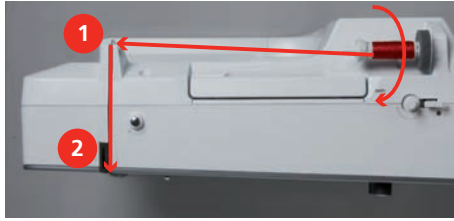

- > Guide the thread downwards (3) around the thread take-up lever cover (4).
- > Guide the thread upwards and insert into the thread take-up lever (5).
- > Guide the thread downwards again (6).

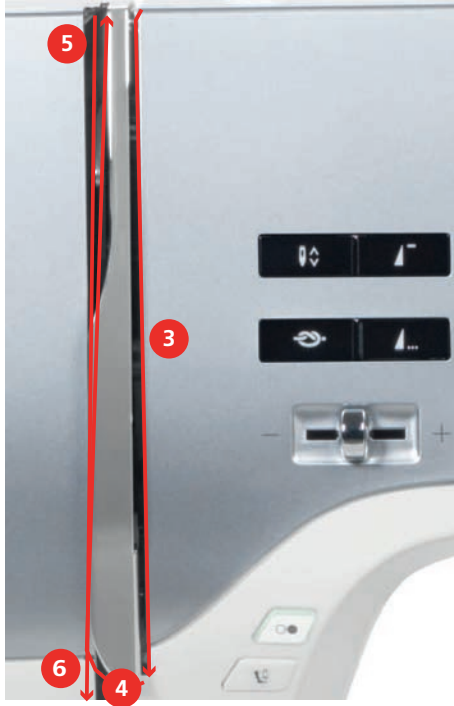

- > Guide the thread through the guides (7/8) above the presser foot.

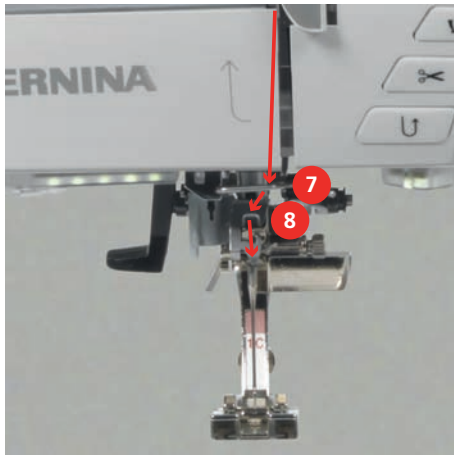

- > Switch the machine on.



- > Pull the thread beneath the presser foot from back to front over the thread cutter (15) and cut.



Threading the Twin Needle

Prerequisite:

- The twin needle is inserted.
- > Guide the first thread in direction of the arrow on the right side of the tension disc (1).
- > Guide the second thread in direction of the arrow on the left side of the tension disc (1).



- > Guide the first and the second thread to the thread guide above the needle.
- > Thread the first thread manually into the right needle.
- > Thread the second thread manually into the left needle.

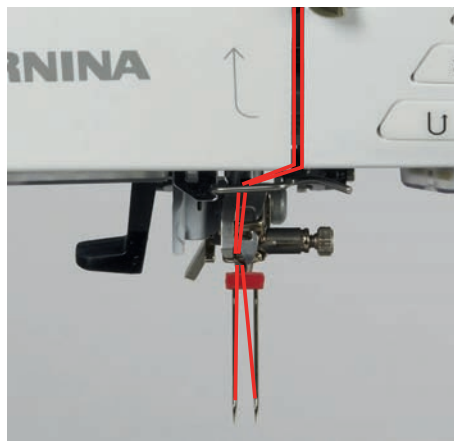

Threading the triple needle

Prerequisite:

- The triple needle is inserted.
- > Place the foam pad, the thread spool and the appropriate spool cap on the horizontal spool pin.
- > Place the foam pad on the vertical spool pin.
- > Attach the filled bobbin on the vertical spool pin so that the silvery sensor surface is down.
- > Attach the thread spool in the opposite direction to the bobbin.



- > Thread the 3 threads up to the upper thread guide.

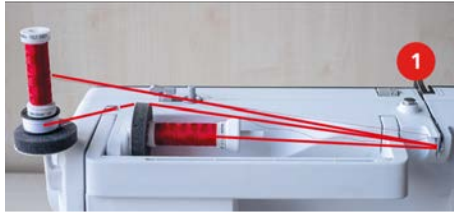

- > Guide 2 threads (vertical spool pin) past the thread tension disc (1) on the left and up to the thread guide above the needle.
- > Guide 1 thread (horizontal spool pin) past the thread tension disc (1) on the right and up to the thread guide above the needle.
- > Thread 1 thread of the vertical thread spool pin into the left and right needle by hand.
- > Thread the thread of the horizontal spool pin into the center needle manually.

Winding the bobbin thread



The bobbin thread can be wound while embroidering if the swiveling spool holder is used for winding.

Prerequisite:

- The foam pad, the thread spool and the appropriate spool disc are fitted.
- > Place the empty bobbin on the Winding Unit (1) so that the silvery sensor surface is down.



- > Guide the thread to the left into the rear thread guide (2).
- > Guide the thread around the bobbin winder pretension clockwise (3).
- > Wind the thread clockwise 2 – 3 times around the empty bobbin (4).

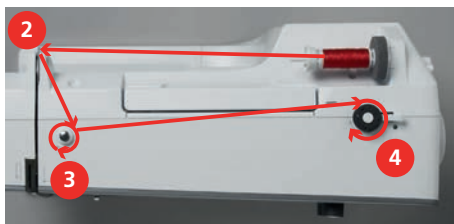

- > Pull the excess thread over the thread cutter at the engaging lever (5) and cut.



- > Push the engaging lever (6) towards the bobbin.

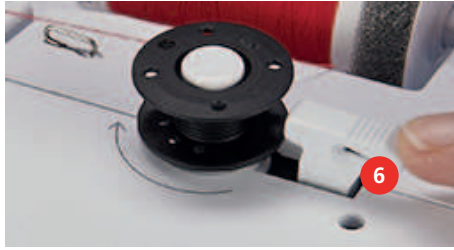

- The machine winds and the display to wind the bobbin appears.
- > Set winding speed.
- > To stop the winding process, the engaging lever must be pushed to the right.
- > Push the engaging lever towards the bobbin again to continue the winding process.
 - As soon as the bobbin is full, the machine stops the winding process automatically.
- > Remove the bobbin and cut the thread using the thread cutter at the engaging lever.

Threading the Bobbin Thread

Prerequisite:

- The needle is raised.
- The machine is switched off and the bobbin cover is opened.
- > Press the bobbin case release at the bobbin case (1).

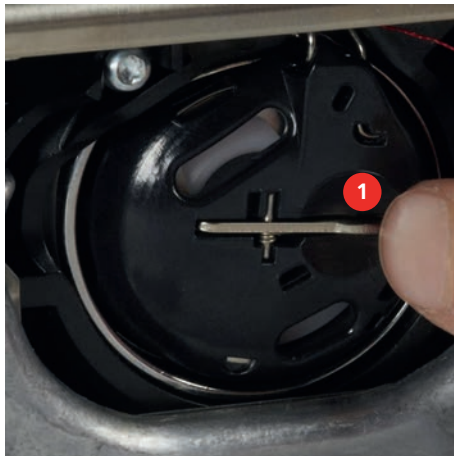

- > Remove the bobbin case.
- > Remove the bobbin from the bobbin case.
- > Insert the new bobbin so that the silvery sensor surface is facing the back of the bobbin case.



3 Setup Program

3.1 Sewing Settings

Adjusting the Upper Thread Tension

Changes to the upper thread tension in the Setup Program affect all of the stitch patterns. The setting in the setup is retained after the machine is switched off.



> Tap «Setup Program».



> Tap «Sewing Settings».



> Tap «Adjusting the Upper Thread Tension».
> Adjust the upper thread tension.

Adjusting the Maximum Sewing Speed

The maximum speed can be reduced by this function.



> Tap «Setup Program».



> Tap «Sewing Settings».



> Tap «Maximum Sewing Speed».
> Set the maximum sewing speed.

Programming Securing Stitches

If the function is switched on, 4 securing stitches are automatically sewn at the start of the pattern after the thread cut.



> Tap «Setup Program».



> Tap «Sewing Settings».



> Switch «Securing Stitches at the Start of the Pattern» on or off.

Adjusting the hovering height of the presser foot

The hovering height of the presser foot can be adjusted according to the fabric thickness from 0 to maximal 7 mm.

Set hovering height = fabric thickness + required clearance between the fabric and the presser foot in the floating position.



> Tap «Setup Program».



> Tap «Sewing Settings».



> Tap «Programming Buttons and Icons».



> Tap «Programming the Hovering Height of the Presser Foot».
> Adjust the distance between the fabric and the presser foot.



Programming the button «Pattern end»

The presser foot can be positioned, the thread cut and the automatic securing can be programmed.



> Tap «Setup Program».



> Tap «Sewing Settings».



> Tap «Programming Buttons and Icons».



> Tap «Programming the Button Pattern End».



> To activate the automatic securing, tap «Securing Stitches».
 > To deactivate automatic securing, tap «Securing Stitches» again.



> To program subsequent securing stitches, tap «Securing Stitches in Close Succession».
 > To program the number of subsequent securing stitches, tap «Plus» or «Minus».



> To program 4 securing stitches in place, tap «Securing Stitches in Place».



> To deactivate the automatic thread cut after securing, tap «Automatic Thread Cutter».
 > To activate the automatic thread cut after securing, tap «Automatic Thread Cutter» again.



> To keep the presser foot in lowered position, tap «Raise the Presser Foot».
 > To raise the presser foot after securing, tap «Raise the Presser Foot» again.

Programming the button «Thread cutter»

The automatic securing can be programmed before the thread cut takes place.



> Tap «Setup Program».



> Tap «Sewing Settings».



> Tap «Programming Buttons and Icons».



> Tap «Programming the Button Thread Cutter».



> To activate the automatic securing, tap «Securing Stitches».
 > To deactivate automatic securing, tap «Securing Stitches» again.



> To program subsequent securing stitches, tap «Securing Stitches in Close Succession».
 > To program the number of securing stitches, tap «Minus» or «Plus».



> To program 4 securing stitches in place, tap «Securing Stitches in Place».

Adjusting the presser foot position with needle stop down



With lowered needle, 3 different presser foot position can be selected: the presser foot lowered, the presser foot is raised to hovering position and the presser foot is raised to its maximum height.



> Tap «Setup Program».









> Tap «Sewing Settings».

-  > Tap «Programming Buttons and Icons».
-  > Tap «Pressure Foot Position with Needle Stop Down».
-  > Select the desired presser foot position.







Programming the button «Quick reverse»

It can be either chosen «Reverse Sewing» or «Backstepping».

-  > Tap «Setup Program».
-  > Tap «Sewing Settings».
-  > Tap «Programming Buttons and Icons».
-  > Tap «Programming the Button Quick Reverse».
-  > To set the stitch-precise reverse sewing, tap «Back Stepping».
-  > To set the reverse sewing, tap «Quick Reverse».



Programming the button «Securing»

The number and type of securing stitches can be programmed.









-  > Tap «Setup Program».
-  > Tap «Sewing Settings».
-  > Tap «Programming Buttons and Icons».
-  > Tap «Programming the Button Securing».
-  > To program subsequent securing stitches, tap «Securing Stitches in Close Succession».
-  > To program the number of securing stitches, tap «Minus» or «Plus».
-  > To program 4 securing stitches in place, tap «Securing Stitches in Place».

Programming the foot control

If «Needle Up/Down» is activated, the needle is raised or lowered with the back-kick on the foot control. Alternatively, the presser foot can be positioned, the thread can be cut and the automatic securing can be programmed.

-  > Tap «Setup Program».
-  > Tap «Sewing Settings».





-  > Tap «Programming the Foot Control».
- 
 - «Needle Up/Down» is activated in the default setting.
 - The back-kick on the foot control raises or lowers the needle.
-  > To program the Back-kick, tap «Programming the Back-kick».
- 
 - > To deactivate the automatic securing via the Back-kick, tap «Securing Stitches».
 - > To activate the automatic securing via the Back-kick, tap «Securing Stitches» again.
- 
 - > To program subsequent securing stitches, tap «Securing Stitches in Close Succession».
 - > To program the number of securing stitches, tap «Minus» or «Plus».
-  > To program 4 securing stitches in place, tap «Securing Stitches in Place».
- 
 - > To deactivate the automatic thread cut via the Back-kick, tap «Automatic Thread Cutter».
 - > To activate the automatic thread cut via the Back-kick, tap «Automatic Thread Cutter» again.
- 
 - > To keep the lowered position of the presser foot via the Back-kick, tap «Raise the Presser Foot».
 - > To keep the raised position of the presser foot via the Back-kick, tap «Raise the Presser Foot» again.

3.2 Embroidery Settings



Adjusting the Upper Thread Tension

Changes to the upper thread tension in the Setup Program affect all of the embroidery designs.

-  > Tap «Setup Program».
-  > Tap «Embroidery Settings».
- 
 - > Tap «Adjusting the Upper Thread Tension».
 - > Adjust the upper thread tension.



Adjusting the Maximum Embroidering Speed



The maximum speed can be reduced by this function.

-  > Tap «Setup Program».
-  > Tap «Embroidery Settings».
- 
 - > Tap «Maximum Embroidery Speed».
 - > Set the maximum sewing speed.

Centering or opening embroidery motifs in the original position

When opening the embroidery motifs on the machine, they are always centered in the Embroidery Hoop. If it is desired to open embroidery motifs in the original position (determined by the BERNINA Embroidery Software), the function «Centering the Embroidery Design» must be activated.

-  > Tap «Setup Program».
-  > Tap «Embroidery Settings».



-  > Tap «Centering the Embroidery Design».
-  > Tap the Switch.
 - A previously moved embroidery motif which has been saved in the new position is opened in the saved position after selecting.
-  > Tap the Switch again.
 - The embroidery motif is centered to the Embroidery Hoop.

Calibrating the embroidery hoop

The calibration of the embroidery hoop is the coordination of the needle to the center of the embroidery hoop.

Prerequisite:

- The embroidery module is connected and the embroidery hoop with the appropriate embroidery template is attached.



-  > Tap «Setup Program».
-  > Tap «Embroidery Settings».
-  > Tap «Calibrating the Embroidery Hoop».
 - The machine recognizes the embroidery hoop automatically.
- > To delete the current calibration, tap «Deleting» (1).
- > Center the needle via the arrow icons on the display.



-  > To save the calibration, tap «Confirm».

Entering the fabric thickness

If the fabric thickness is more than 4 mm as for e.g. toweling, it is recommended to select 7.5 mm or 10 mm. The thicker the fabric, the slower the embroidery speed of the machine. When the machine is switched off, the alterations are reset to the basic setting 4 mm.

-  > Tap «Setup Program».
-  > Tap «Embroidery Settings».
-  > Tap «Entering the Fabric Thickness».
 - > Select fabric thickness.

Activating/Deactivating the function thread away

To bring up the thread end after cutting and to pull it out of the fabric, the function must be activated. For embroidery motifs with long stitches it is recommended to deactivate the function Thread Away. If the distance between the presser foot and the embroidery hoop is too small, the function will not be carried out.



> Tap «Setup Program».



> Tap «Embroidery Settings».



> Tap «Thread Away».



> Activating/Deactivating the function thread away.

Programming the securing stitches

Embroidery motifs are programmed either with or without securing stitches. If an embroidery motif has programmed securing stitches, they will be embroidered. If the embroidery motif is programmed with securing stitches, the securing stitches can be removed in the BERNINA Embroidery Software.

The machine recognizes when no securing stitches are programmed and adds them. If no securing stitches are wanted, they can be deactivated.



> Tap «Setup Program».



> Tap «Embroidery Settings».



> Tap «Securing Stitches».



> To deactivate the securing stitches at the start, switch off the switch in the upper section.

– If the embroidery motif doesn't have any programmed securing stitches, none are embroidered.



> Turn on the switch in the upper section to deactivate the securing stitches at the start.

– If the embroidery motif doesn't have any programmed securing stitches, the securing stitches are added and will be embroidered.



> Turn off the switch in the lower section to deactivate the securing stitches at the end.

– If the embroidery motif doesn't have any programmed securing stitches, none are embroidered.



> Turn on the switch in the lower section to activate the securing stitches at the end.

– If the embroidery motif doesn't have any programmed securing stitches, the securing stitches are added and will be embroidered.

Adjusting the thread cut

The settings for the thread cut can be customized. Deactivate the thread cut before a color change (1) or adjust the length of the connecting stitch (3). The machine does the cutting of the connecting threads at the determined length for you. First, set the length from which the connecting stitches are cut, and then select the embroidery design.



The length of the connecting thread can be adjusted between 1 mm and 15 mm, the default setting is 6 mm. This means that all connecting stitches longer than 6 mm are cut automatically. If the value is reduced to 1 mm, more thread cuts are carried out, it takes longer to embroider and more loose thread ends can be seen on the wrong side of the fabric, especially when the function 'Thread-away' is activated too. On the right side of the fabric there will be practically none or merely very short connecting stitches which results in a wonderful stitch formation. Reducing the length of the thread cut to 1 mm is particularly of advantage when embroidering texts where usually many short connecting threads occur. When both sides of the embroidery designs are visible, it may be reasonable to not reduce the length of the thread cut so much so that there won't be too many loose thread ends on the wrong side of the fabric. Loose ends get sewn over and can hardly be removed afterwards.



> Tap «Setup Program».



> Tap «Embroidery Settings».



> Tap «Thread Cut Settings».



- > To deactivate the automatic thread cut before changing a thread, tap the switch in the upper section of the display (1).
- > To activate the automatic thread cut before changing a thread, tap the switch in the upper section of the display (1) again.
- > Tap the switch in the middle section of the display (2) so that the machine will stop after about 7 stitches and the remaining thread can be cut manually.
- > Tap the switch in the middle section of the display (2) again and the machine won't stop for a manual thread cut.
- > To adjust the length from where the connecting stitches are cut, tap «Minus» or «Plus» (3).

Changing the measuring unit

The measuring unit in the Embroidery Mode can be changed from mm to inch. The standard setting is in mm.



> Tap «Setup Program».



> Tap «Embroidery Settings».



- > Tap «Measuring Unit».
- > To display the measurements in the Embroidery Mode in inch, tap «inch».
- > To display the measurements in the Embroidery Mode in mm, tap «mm».

3.3 Selecting personal settings



> Tap «Setup Program».



- > Tap «Personal Settings».
- > Select the required display color and background.
- > Tap the text box above the color settings.
- > Enter and confirm the welcome text.

3.4 Monitoring Functions

Activating the Upper Thread Indicator



> Tap «Setup Program».



> Tap «Monitoring Functions».



- > Tap the switch in the upper section of the display to deactivate the upper thread indicator.
- > Tap the switch again to activate the upper thread indicator.

Activating the Bobbin Thread Indicator



> Tap «Setup Program».









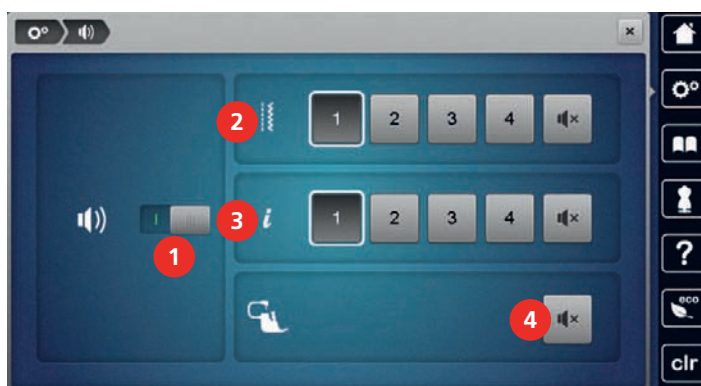

> Tap «Monitoring Functions».



- > Tap the switch in the lower section of the display to deactivate the bobbin thread indicator.
- > Tap the switch again to activate the bobbin thread indicator.

3.5 Activating the audio signals







-  > Tap «Setup Program».
-  > Tap «Setting Sound».
-  > To switch all audio signals on or off, tap (1).
-  > To switch off the sound when selecting a stitch pattern, tap the corresponding «Switching Sounds On/Off» in area (2).
-  > To switch on the sound when selecting a stitch pattern, tap the corresponding in area_(2) «1 – 4».
-  > To switch off the sound for selecting functions, tap the corresponding «Switching Sounds On/Off» in area (3).
-  > To switch on the sound for selecting functions, tap the corresponding in area_(3) «1 – 4».
-  > To deactivate the sound of the beeper when using the BSR Modes, tap «Switching Sounds On/Off» in the sector (4).

3.6 Machine Settings





Selecting a language

The User Interface can be programmed in different languages according to the customer's wish because BERNINA provides a wide range of international languages for the customers. Via firmware updates additional languages for the User Interface can be provided.

-  > Tap «Setup Program».
-  > Tap «Machine settings».
-  > Tap «Language Selection».
-  > Select a language.







Adjusting the Brightness of the Display

The brightness of the display can be set to meet your individual needs.

-  > Tap «Setup Program».
-  > Tap «Machine settings».
-  > Tap «Display Settings».
-  > Adjust the brightness of the display in the upper section of the screen.

Adjusting the Sewing Light

The brightness of the sewing light can be adjusted corresponding to the personal preferences.

-  > Tap «Setup Program».
-  > Tap «Machine settings».
-  > Tap «Display Settings».
-  > Adjust the brightness of the sewing light in the lower section of the screen.
-  > Tap the switch to switch the sewing light off.
-  > Tap the switch again to switch the sewing light on.

Calibrating the Display

You will find more information on this topic in the chapter “Troubleshooting”. (see page 173)

Setup Program



> Tap «Setup Program».



> Tap «Machine settings».



> Tap «Calibrating the Screen».

> Touch the crosses in sequence using the touchscreen pen.

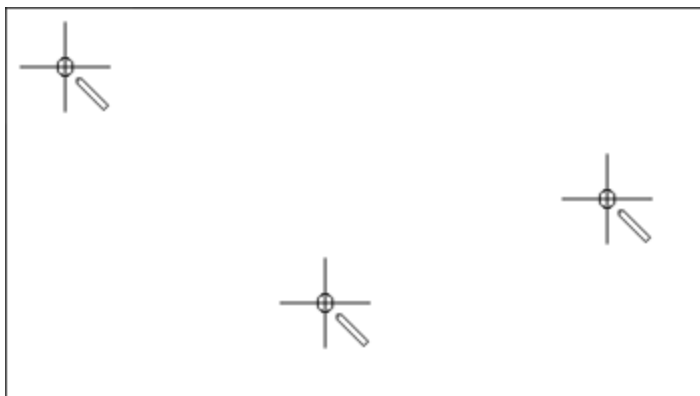

Back to Basic Setting

ATTENTION: Using this function will delete all individually made settings.



> Tap «Setup Program».



> Tap «Machine settings».



> Tap «Factory Setting».



> To restore all default settings for sewing, tap «Default Setting Sewing» and confirm.



> To restore all default settings for embroidering, tap «Default Setting Embroidering» and confirm.



> To restore all default settings, tap «Default Setting Machine», confirm and restart the machine.

Deleting user data



> Tap «Setup Program».



> Tap «Machine settings».



> Tap «Factory Setting».



> To delete all data from the Personal Memory, tap «Delete Data from Own Storage Medium» and confirm.



> To delete all embroidery motifs from the Personal Memory, tap «Delete Personal Embroidery Designs» and confirm.

Deleting motifs on the BERNINA USB Stick

> Insert the BERNINA USB stick into the USB Port of the machine.



> Tap «Setup Program».



> Tap «Machine settings».

 > Tap «Factory Setting».

 > Tap «Deleting USB Stick» and confirm.

Calibrating the Buttonhole Foot #3A

The Buttonhole Foot with Slide #3A is calibrated to the machine and they should only be used both together.

Prerequisite:

- The Buttonhole Foot with Slide #3A is fitted.
- The needle is not threaded.

 > Tap «Setup Program».

 > Tap «Machine settings».

 > Tap «Maintenance/update».

 > Tap «Calibrating the Buttonhole Foot #3A».

 > To start the calibration, push the button «Start/Stop».
– When the calibration is complete, the result is shown in the display.

Packing the embroidery module

To pack the embroidery module into the original packaging without moving the embroidery arm manually, the embroidery arm needs to be brought to its packing position.

Prerequisite:

- The embroidery module is connected with the machine.

 > Tap «Setup Program».

 > Tap «Machine settings».

 > Tap «Maintenance/update».

 > Tap «Packing Position».
> Follow the instructions on the display.

Reviewing the total number of stitches

The total number of stitches by the machine and the number of stitches since the last maintenance carried out by a specialist BERNINA dealer are displayed.

 > Tap «Setup Program».









 > Tap «Machine settings».

 > Tap «Information».

 > Tap «Machine Data».





Registering details of the dealer

The contact details for your specialized BERNINA dealer can be entered.

-  > Tap «Setup Program».
-  > Tap «Machine settings».
-  > Tap «Information».
-  > To enter the dealer data, tap «Dealer Data».
-  > To enter the name of your specialized BERNINA dealer, tap «Name».
-  > To enter the address of the specialized BERNINA dealer, tap «Address».
-  > To enter the telephone number of the specialized BERNINA dealer, tap «Phone Number».
-  > To enter the website or e-mail address of the specialized BERNINA dealer, tap «E-mail address».

Saving Service data

The service data regarding the current status of the machine can be saved on a USB stick and consequently provided to the specialized BERNINA dealer.

- > Insert a USB stick which provides enough free capacity into the USB port of the machine.
-  > Tap «Setup Program».
-  > Tap «Machine settings».
-  > Tap «Information».
-  > Tap «Service Data».
-  > Tap «Export the Service Data».
 - The icon «Export the Service Data» is outlined in white.
- > If the white frame is no longer displayed, remove the USB stick.

4 System Settings

4.1 Calling Up the Tutorial

The Tutorial gives information and explanations, covering various aspects of sewing, embroidering, and the different stitches.



- > Tap «Tutorial».
- > Select the desired topic in order to view information.

4.2 Calling up the Creative Consultant

The Creative Consultant provides decision support for sewing projects. After entering the kind of fabric and the desired sewing project, suggestions concerning the suitable needle or the appropriate presser foot are displayed.



- > Tap «Creative Consultant».
- > Select the fabric on which you want to sew.
- > Select the sewing project.



- > Tap «Confirm».
- The settings are adjusted.

4.3 Calling up the Embroidery Consultant

The Embroidery Consultant informs you about decision support for embroidery projects. After entering the desired embroidery project and the fabric, suggestions for the suitable needle and the suitable embroidery foot are displayed.



- > Tap «Embroidery Consultant».
- > Select the embroidering project.
- > Select the fabric on which you want to embroider.



- > Tap «Confirm».
- If an embroidery motif has already been selected, a warning appears stating that this will be overwritten.

4.4 Calling Up the Help



- > Touch the window in the display where help is needed.
- > To start the Help Mode, tap «Help» twice.
- > Tap the icon in the display where help is needed.

4.5 Using eco mode

During a longer interruption of work the machine can be set into a power save mode. The power save mode also serves as a child safety feature. Nothing can be selected in the display and the machine cannot be started.



- > To activate the power save mode, tap «eco Mode».
- The display goes to sleep. The power consumption is reduced and the sewing light is off.
- > To deactivate the power save mode, tap «eco Mode» again.

4.6 Cancelling Any Alterations with «clr»

Any alterations to designs can be reset to basic setting. Exceptions are saved designs which have been filed in the personal memory and monitoring functions.



- > Tap «Clear Settings».

5 Creative Sewing

5.1 Overview selection menu sewing



- | | | | |
|---|-----------------------|---|-------------------|
| 1 | «Practical Stitches» | 5 | «Quilt Stitches» |
| 2 | «Decorative Stitches» | 6 | «Personal Memory» |
| 3 | «Alphabets» | 7 | «History» |
| 4 | «Buttonholes» | | |

Selecting a stitch pattern

- > Select a stitch pattern, alphabet or buttonhole.
- > To increase the view, tap «Increasing/Decreasing the Display Size» (1).



- > To decrease the view, tap «Increasing/Decreasing the Display Size» again.
- > To select the stitch pattern via the stitch number entry, tap «Stitch Pattern Selection via Number».

5.2 BERNINA Dual Feed

The BERNINA Dual Feed feeds the fabric from above and from beneath simultaneously. This provides an even and careful feed forward even for smooth and thin materials. Striped and checkered patterns can be matched perfectly by even feeding.

In general, the BERNINA Dual Feed is used for the following sewing projects:

- Sewing: All sewing applications with difficult fabrics, e. g. seams, zippers.
- Patchwork: With accurate stripes, blocks and with decorative stitches up to a stitch width of 9 mm.
- Appliqués: Sewing on ribbons and bias binding.

Difficult-to-work-with fabrics are:

- Velvet, normally sewn with the grain.
- Toweling.
- Jersey, especially when sewing it crosswise to knit.
- Fake fur or coated fake fur.
- Fleece-types of fabrics.

5.4 Adjusting the upper thread tension

The default setting of the upper thread tension is set automatically as soon as a stitch pattern or an embroidery motif is selected.

The upper thread tension is set optimally at the BERNINA factory and the machine has been tested. Metrosene-/Seralon thread size 100/2 (Company Mettler, Switzerland) is used for upper and bobbin thread.

When of using other types of sewing or embroidery threads, the optimal tension may vary. Therefore it may be necessary to adjust the upper thread tension according to the sewing or embroidering project as well as the desired stitch pattern or the embroidery motif individually.

The higher the upper thread tension, the tighter the upper thread which means that the bobbin thread is pulled up to the top of the fabric. When the upper thread tension is low, the upper thread is less tightened which means that the bobbin thread is pulled up less.

Alteration to the upper thread tension affect the currently selected stitch pattern or embroidery motif. Permanent alterations of the upper thread tension for the Sewing Mode (see page 49) and for the Embroidering Mode (see page 52) can be made in the Setup Program.

Prerequisite:

- The upper thread tension has been altered in the setup program.



- > Tap «Upper Thread Tension».
- > Adjust the upper thread tension.



- > Tap the yellow-outlined icon on the right side to reset the alterations to the default setting.
- > Tap the yellow-outlined icon on the left side to reset the alteration to default setting in the **Setup Program**.

5.5 Editing Stitch Patterns

Changing the Stitch Width

- > Turn the «Upper Multi-function Knob» to the left to narrow the stitch width.
- > Turn the «Upper Multi-function Knob» to the right to widen the stitch width.
- > To call up further setting options, tap the icon «Stitch width» (1).

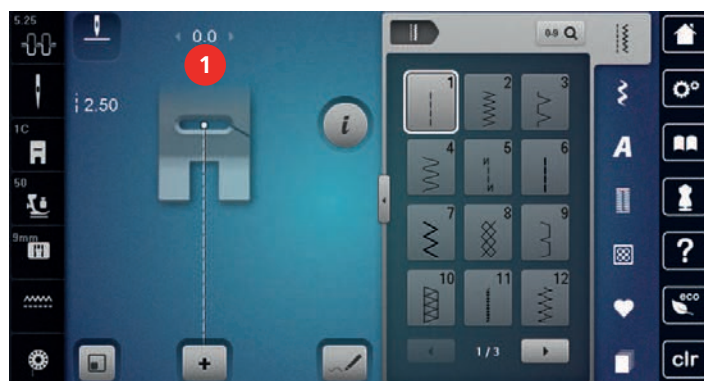

Changing the Stitch Length

- > Turn the «Lower Multi-function Knob» to the left to shorten the stitch length.
- > Turn the «Lower Multi-function Knob» to the right to elongate the stitch length.
- > To call up other setting options, tap «Stitch Length» (1).



Correcting the Balance

Different fabrics, threads and stabilizers can affect the programmed stitch patterns so that they cannot be sewn out correctly. The electronic balance can correct these deviation and the stitch pattern can be adjusted optimally to the selected fabric.

- > Select a stitch pattern or alphabet.
- > Sewing stitch pattern.
- > Tap «i-Dialog».



- > Tap «Balance».
 - A preview of the stitch pattern is displayed.

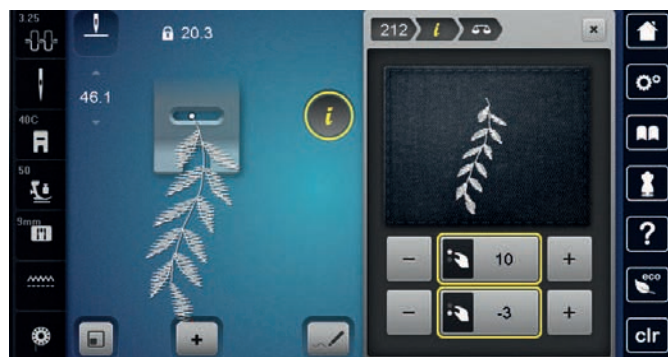

- > Turn the «Upper Multifunction knob» to correct the horizontal direction of the stitch pattern.
 - > To correct the longitudinal direction of the stitch pattern, turn the «Lower Multi-function Knob» until the preview of the stitch pattern matches the stitch pattern sewn on the fabric.
-  > Altered Balance settings can be saved for each stitch in the «Personal Memory» .
- > Altered Balance settings only remain valid until the «Clear Settings» is pushed or the machine is switched off.

Programming pattern repeat

Stitch patterns as well as stitch pattern combinations can be repeated up to 9 times.

- > Select a stitch pattern or alphabet.
- > Tap «i-Dialog».



- > To sew the stitch pattern 1x, tap «Pattern Repeat» 1x.
- > To repeat the stitch pattern up to 9 times, tap «Pattern Repeat» 2 up to 9x.
- > To deactivate the pattern repeat, tap and hold «Pattern Repeat».

Programming long stitch

The maximum length for long stitches is 12 mm and the machine sews every second stitch.



- > Select a stitch pattern.
- > Tap «i-Dialog».



- > Tap «Long Stitch».

Mirror Image of Stitch Patterns



- > Select a stitch pattern or alphabet.
- > Tap «i-Dialog».



- > To mirror the stitch pattern from left to right, tap «Mirror Image Left/Right».



- > To mirror the stitch pattern in sewing direction, tap «Mirror Image Up/Down».

Edit Stitch Pattern Length

The stitch patterns can be lengthwise extended or shortened.



- > Select a stitch pattern or alphabet.
- > Tap «i-Dialog».



- > Tap «Edit Stitch Pattern Length».
- > Adjust the stitch pattern length.

Programming the Stitch Counter Function

The Stitch Counter function cannot be set for all stitch patterns. If, for example, the Honeycomb Stitch No. 8 is selected, the stitch counter function cannot be used.



- > Select the stitch pattern.
- > Tap «i-Dialog».



- > Tap «Programming the Length via the Stitch Counter».
- > Sew the desired length.



- > Push the button «Quick Reverse».
 - The display changes to «Auto» and the selected stitch pattern in the new length is saved until the machine is switched off.

Quick Reverse

- > Select a stitch pattern or alphabet.
- > To switch immediately to sewing in reverse when pushing the button «Quick Reverse», select Needle Stop Down (permanent).
- > Program needle stop up (permanent) to sew another stitch forward before the machine switches to reverse sewing.
- > Push and hold the button «Quick Reverse».

Permanent Quick Reverse

- > Select a stitch pattern or alphabet.

 > Tap «i-Dialog».

 > To sew permanently in reverse, tap «Quick Reverse».
– The machine sews permanently in reverse until «Quick Reverse» is tapped again.

Backstepping

> Select a stitch pattern or alphabet.
> Tap «i-Dialog».

 > To backstep the last 200 stitches, tap «Back Stepping».

Changing the sewing direction

> Select a stitch pattern or alphabet.
> Tap «i-Dialog».

 > Tap «Changing the Sewing Direction».
> Use the «Upper Multi-function Knob» or «Lower Multi-function Knob» to rotate the stitch pattern in 0.5° steps.
> Rotate the stitch pattern or the alphabet via the icon «Directional Sewing» (1) in 45° steps.



5.6 Combining stitch patterns

Overview Combi mode



1 «Stitch Pattern View Fit to Screen»

2 «Combination Mode/Single Mode»

3 «Edit Mode/Extended Edit Mode»

4 Individual Stitch Pattern within the Combination

Overview Combi mode extended

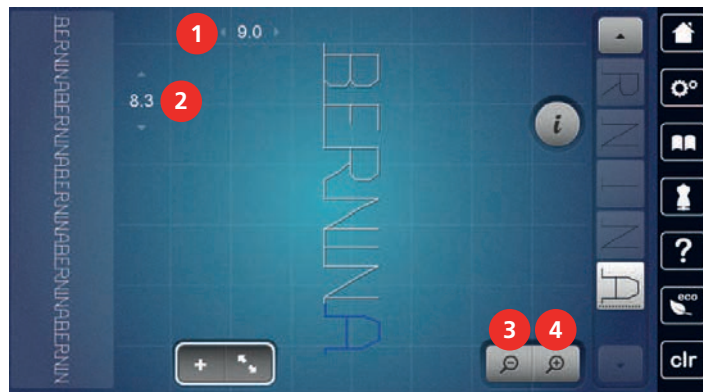

- | | | | |
|---|-----------------|---|------------|
| 1 | «Stitch Width» | 3 | «Zoom Out» |
| 2 | «Stitch Length» | 4 | «Zoom In» |

Creating Stitch Pattern Combinations

In the Combi Mode stitch patterns and alphabets can be combined according to your wish. By combining any alphabet letters, the logo BERNINA can be created.



- > Tap «Combination Mode/Single Mode».
- > Select the desired stitch patterns.



- > To get back to the Single Mode, tap «Combination Mode/Single Mode» again.

Saving a Stitch Pattern Combination

To use an individually created stitch pattern combinations again, they can be saved in the folder «Personal Memory».

Prerequisite:

- A stitch pattern combination has been created.



- > Tap «Personal Memory».



- > Tap «Save Stitch Pattern».



- > To save the stitch pattern combination, tap «Confirm».

Loading a Stitch Pattern Combination



- > Tap «Combination Mode/Single Mode».

Editing a Single Stitch Pattern

Prerequisite:

- A stitch pattern combination has been created.
- > To select a single stitch pattern, tap the desired position (1) within the stitch pattern combination.



- > To edit the single stitch pattern, tap «i-Dialog».

Deleting a single stitch pattern

Prerequisite:

- A stitch pattern combination has been created.
- > Tap the desired stitch pattern (1) within the stitch pattern combination.

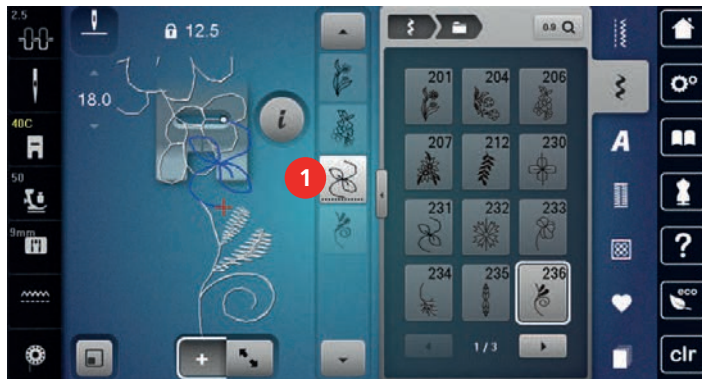

- > Tap «i-Dialog».



- > Tap «Deleting».

Adding a Single Stitch Pattern

The new stitch pattern is always inserted after the selected stitch pattern.

Prerequisite:

- A stitch pattern combination has been created.

- > To select a single stitch pattern, tap the desired position (1) within the stitch pattern combination.



- > Select a new stitch pattern.

Relocating a single stitch pattern

Prerequisite:

- A stitch pattern combination has been created.



- > Tap «Edit Mode/Extended Edit Mode».
- > Tap the desired stitch pattern within the stitch pattern combination.



- > Tap «i-Dialog».



- > Tap «Relocating a Stitch Pattern».
- > Relocate the stitch pattern.
 - The connecting stitches between the stitch patterns are added automatically.

Adapting the Stitch Pattern length and Stitch Pattern Width

The length and width of the individual stitch patterns in a stitch pattern combination can be adapted to the longest and widest stitch patterns in the combination.

Prerequisite:

- A stitch pattern combination has been created.



- > Tap «i-Dialog».



- > Tap «Edit Entire Combination».
- > Tap «Total Pattern Length» (1).



- > Tap «Adjust Length within the Combination» (2).
 - The lengths of the stitch patterns are adapted to the length of the longest stitch pattern in the combination.

- > Tap «Stitch Width» (3).



- > Tap «Adjust Width within the Combination» (4).
 - The widths of all of the stitch patterns are adapted to the width of the widest stitch pattern in the combination.

Furthermore, the length and width of the stitch pattern combination are increased or decreased proportionally.

- > To decrease the width of the stitch pattern combination proportionally, turn the «Upper Multi-function knob» to the left.
- > To increase the width of the stitch pattern combination proportionally, turn the «Upper Multi-function knob» to the right.
- > To decrease the length of the stitch pattern combination proportionally, turn the «Lower Multi-function knob» to the left.
- > To increase the length of the stitch pattern combination proportionally, turn the «Lower Multi-function knob» to the right.

Mirroring a Stitch Pattern Combination

Prerequisite:

- A stitch pattern combination has been created.



- > Tap «i-Dialog».



- > Tap «Edit Entire Combination».



- > To mirror the whole stitch pattern combination from left to right, tap, «Mirror Image Left/Right».
- > To reset the changes and revert to the default settings, tap «Mirror Image Left/Right».

Stitch Pattern Combination Subdivider 1

A stitch pattern combination can be subdivided into several sections. The subdivision is inserted below the cursor. Only the section in which the cursor is placed will be sewn. To sew the next section, the cursor must be placed in this section.

Prerequisite:

- A stitch pattern combination has been created.
- > Select the desired position within the stitch pattern combination where the stitch pattern combination is to be subdivided.



- > Tap «i-Dialog».



- > Tap «Edit Combination at Cursor Position».



> Tap «Edit Entire Combination».



- > To repeat the stitch pattern combination, tap «Pattern Repeat» 1x.
- > To repeat the stitch pattern combination up to 9x, tap «Pattern Repeat» again.
- > To deactivate the pattern repeat, tap and hold «Pattern Repeat» or tap «Clear Settings».

Changing the sewing direction of a stitch pattern

Prerequisite:

- A stitch pattern combination has been created.



- > Tap «Edit Mode/Extended Edit Mode».
- > Select the desired stitch pattern within the stitch pattern combination.



> Tap «i-Dialog».



- > Tap «Changing the Sewing Direction».
- > To rotate the stitch pattern combination in 0.5° steps, turn the «Upper Multi-function Knob» or «Lower Multi-function Knob».

Changing the sewing direction of a stitch pattern combination

Prerequisite:

- A stitch pattern combination has been created.



> Tap «Edit Mode/Extended Edit Mode».



> Tap «i-Dialog».



> Tap «Edit Entire Combination».



- > Tap «Changing the Sewing Direction».
- > To rotate the stitch pattern combination in 0.5° steps, turn the «Upper Multi-function Knob» or «Lower Multi-function Knob».

5.7 Administering Stitch Patterns

Saving Settings of Stitch Patterns



- > Select a stitch pattern, alphabet or buttonhole.
- > Tap «i-Dialog».
- > Edit the stitch, alphabet or buttonhole.



> To save all alterations permanently, tap «Saving Settings of Stitch Patterns».



> To cancel all alterations, tap «Reset Stitch Pattern».

Calling up the previously sewn stitch patterns

The 15 previously sewn stitch patterns are saved automatically and can be called up at any time.



- > To display the previously sewn stitch patterns, tap «History».
- > Select a stitch pattern.

Saving Stitch Patterns in Personal Memory

In the folder «Personal Memory» any stitch patterns, also those which have been individually edited, can be saved.

- > Select a stitch pattern, alphabet or buttonhole.
- > Edit the stitch pattern.
- > Tap «Personal Memory».



- > Tap «Save Stitch Pattern».
- > Select the file where the pattern is to be saved.



- > Tap «Confirm».

Overwriting Stitch Patterns from the Personal Memory

Prerequisite:

- The stitch pattern is saved in the personal memory.

- > Select a stitch pattern, alphabet or buttonhole.
- > Edit the stitch pattern.
- > Tap «Personal Memory».



- > Tap «Save Stitch Pattern».
- > Select the file where the stitch pattern to be overwritten has been saved.
- > Select the stitch pattern which should be overwritten.



- > Tap «Confirm».

Loading Stitch Patterns from the Personal Memory

Prerequisite:

- The stitch pattern is saved in the personal memory.

- > Tap «Personal Memory».



- > Tap «Load Embroidery Design».
- > Select the file where the stitch pattern has been saved.
- > Select the stitch pattern.

Deleting Stitch Patterns from the Personal Memory

Prerequisite:

- The stitch pattern is saved in the personal memory.

- > Tap «Personal Memory».



- > Tap «Deleting».
- > Select the file where the stitch pattern has been saved.
- > Select the stitch pattern.



- > To delete the stitch pattern, tap «Confirm».

Saving Stitch Patterns on the BERNINA USB Stick

On the BERNINA USB stick stitch patterns, also those which have been individually edited, can be saved.

- > Select a stitch pattern or alphabet.
- > Editing stitch patterns.
- > Tap «Personal Memory».



5.8 Stitch Designer

Overview Stitch Designer



- | | | | |
|---|---------------------|----|------------------------------|
| 1 | «Undo Entries» | 7 | «Limiting Pattern Width» |
| 2 | «Redo Entries» | 8 | «Move View» |
| 3 | Point Position | 9 | «Relocating the Points» |
| 4 | «Zoom Out» | 10 | «Inserting/Editing a Stitch» |
| 5 | «Zoom In» | 11 | «Scrolling Through Points» |
| 6 | Stitch Pattern View | | |

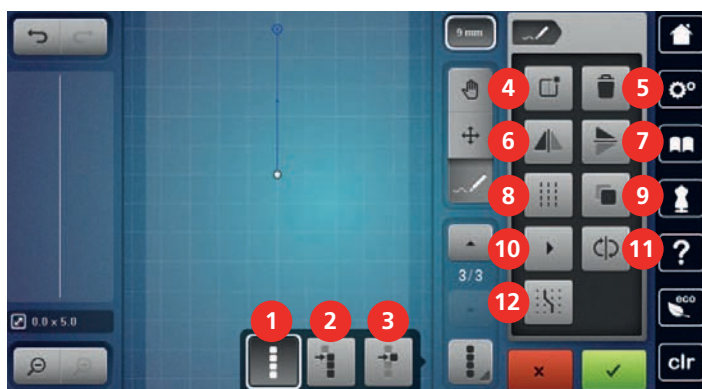

- | | | | |
|---|-------------------------------------|----|---------------------------------|
| 1 | «Select all Points» | 7 | «Mirror Image Up/Down» |
| 2 | «Selecting from a Particular Point» | 8 | «Triple Stitch» |
| 3 | «Single Point is Selected» | 9 | «Duplicating» |
| 4 | «Creating a New Stitch Pattern» | 10 | «Virtual Sewing Out» |
| 5 | «Deleting» | 11 | «Reversing the Stitch Sequence» |
| 6 | «Mirror Image Left/Right» | 12 | «Engaging at the Grid» |

Creating your own stitch pattern







The stitch patterns which have been created in the Stitch Designer can be saved in your «Personal memory».

The Stitch Designer allows creating your personal stitch patterns as well as editing existing stitch patterns. You can create your own stitch patterns on the display by free movement.







In the left portion of the display the position of the currently active point is indicated additionally: The horizontal distance of the point to the center line is indicated in millimeters. The vertical distance of the point to the previous point is also indicated in millimeters.

-  > Tap «Stitch Designer».
-  > Tap «Creating a New Stitch Pattern».
- > Add a point on the display.
- > Add more points on the display as desired.
-  > Tap «Confirm».





Editing the View

- > Select a stitch pattern, alphabet or buttonhole.
-  > Tap «Stitch Designer».
-  > To minimize the stitch pattern view, tap «Zoom Out».
-  > To enlarge the minimized stitch pattern view, tap «Zoom In».
-  > Tap «Move View».
- > Moving the view of the design.

Inserting points





- > Select a stitch pattern, alphabet or buttonhole.
-  > Tap «Stitch Designer».
-  > To show grid points, tap «Engaging at the Grid».
- Every inserted point is automatically placed on the nearest grid point.
-  > To select the point after which a new one is to be inserted, touch «Scroll Up».
-  > To select the point after which a new one is to be inserted, touch «Scroll Down».
- > Insert further points.
-  > To undo the last work step, tap «Undo Entries».
-  > To redo the last work step, tap «Redo Entries».

Relocating the points







- > Select a stitch pattern, alphabet or buttonhole.
-  > Tap «Stitch Designer».
-  > Tap «Single Point is Selected».
-  > Tap «Selecting from a Particular Point».
-  > To add the previous point to the selection, tap «Scroll Up».
-  > To add the following point to the selection, tap «Scroll Down».
- > To move the selected points horizontally, turn the «Upper Multi-function Knob».
- > To move the selected points vertically, turn the «Lower Multi-function Knob».

Duplicating points







- > Select a stitch pattern, alphabet or buttonhole.
-  > Tap «Stitch Designer».

-  > Tap «Single Point is Selected».
-  > Tap «Selecting from a Particular Point».
-  > To add the previous point to the selection, tap «Scroll Up».
-  > To add the following point to the selection, tap «Scroll Down».
-  > Tap «Duplicating».







Deleting points

-  > Select a stitch pattern, alphabet or buttonhole.
-  > Tap «Stitch Designer».
-  > Tap «Single Point is Selected».
-  > Tap «Selecting from a Particular Point».
-  > To add the previous point to the selection, tap «Scroll Up».
-  > To add the following point to the selection, tap «Scroll Down».
-  > To delete all selected points of the stitch pattern, tap «Deleting».

Activating the triple stitch

-  > Select a stitch pattern, alphabet or buttonhole.
-  > Tap «Stitch Designer».
-  > Tap «Selecting from a Particular Point».
-  > To select the previous point, tap «Scroll Up».
-  > To select the following point, tap «Scroll Down».
-  > To set the triple stitch for the marked points, tap «Triple Stitch».

Mirror image of stitch patterns

-  > Select a stitch pattern, alphabet or buttonhole.
-  > Tap «Stitch Designer».
-  > Tap «Single Point is Selected».
-  > Tap «Select all Points».
-  > To mirror all points in the transverse direction, tap «Mirror Image Left/Right».
-  > To mirror all points in the longitudinal direction, tap «Mirror Image Up/Down».

Reversing the stitch sequence



- > Select a stitch pattern, alphabet or buttonhole.
- > Tap «Stitch Designer».



- > Tap «Single Point is Selected».



- > Tap «Select all Points».



- > Tap «Reversing the Stitch Sequence».

Designing a stitch pattern from scratch



- > Select a stitch pattern, alphabet or buttonhole.
- > Tap «Stitch Designer».



- > Tap «Virtual Sewing Out».

Determining the stitch pattern width

The width of the stitch pattern is limited to 9 mm. To sew wider patterns, for example Sideways Motion patterns, it is necessary to deactivate the limitation.



- > Select a stitch pattern, alphabet or buttonhole.
- > Tap «Stitch Designer».

9 mm

- > To deactivate the limitation, tap «Limiting Pattern Width».
- > To activate the limitation, tap «Limiting Pattern Width» again.

5.9 Securing Stitches

Securing a seam with the button «Securing»

The «Securing Stitches» button can be programmed with various securing stitches.



- > Pressing the «Securing Stitches» button before starting to sew.
 - The stitch pattern/stitch pattern combination is secured with the number of programmed stitches when sewing is started.
- > Press the «Securing Stitches» button while sewing.
 - The machine stops immediately and secures with the number of programmed stitches.

Securing with the Button «Pattern End»

The «Pattern End» button can be programmed with various securing stitches.



- > Push the button «Pattern End» before sewing is started or while sewing.
 - While sewing, a stop icon indicates that the function is activated and the stitch pattern or the current combination of a stitch pattern will be secured at the end with the programmed number of stitches.

5.10 Height Compensation of Uneven Layers

If the presser foot is at an angle when sewing over a thick seam, the feed dog cannot grip the fabric and the sewing project cannot be sewn out properly.

- > Place 1 – 3 compensating plates as required from the back of the presser foot close to the needle to level the fabric layer.

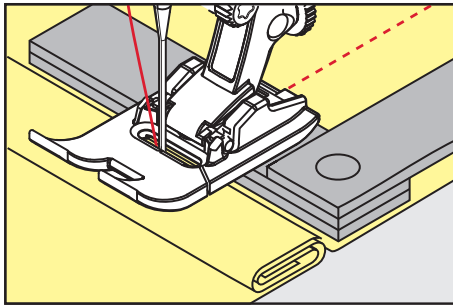

- The presser foot is leveled with the sewing project.

- > Place 1 – 3 compensating plates as required from the front of the presser foot close to the needle to level the fabric layer.

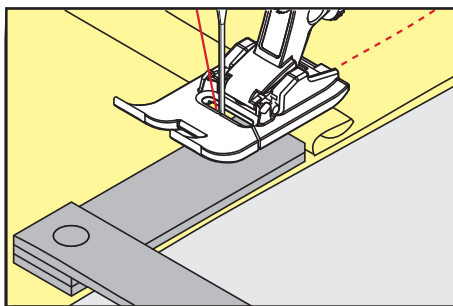

- The presser foot is leveled with the sewing project.

- > Sew until the complete presser foot has passed the thick seam.
- > Remove the plates of the height compensation.

5.11 Sewing Corners

When sewing corners, only a small section of the fabric is actually on the feed dog. Therefore it cannot grip the fabric well. By means of the height compensation tool the fabric can be fed evenly.

- > When the fabric edge is reached, stop the sewing process with needle position down.
- > Raise the presser foot.
- > Turn the fabric and place in desired position.
- > Place 1 – 3 compensating plates as required on the right of the presser foot close to the sewing project.
- > Lower the presser foot.

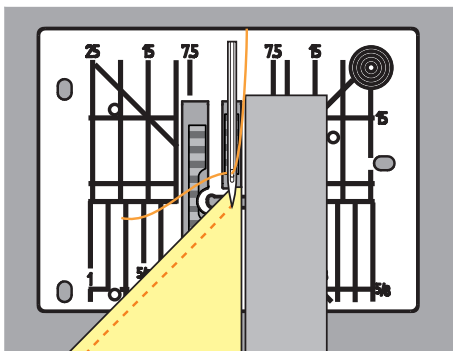















- > Resume sewing until the sewing project is on the feed dog again.

6 Practical Stitches

6.1 Overview Practical Stitches



Stitch patterns	Stitch number	Name	Description
---	1	Straight Stitch	To join seams, for topstitching and basting.
W	2	Zigzag	To finish edges, to sew elastic seams, to sew on lace inserts and elastics.
V	3	Vari-Overlock	For finishing edges, sewing together and simultaneously finishing elastic fabrics.
W	4	Running Stitch	For darning and reinforcing fabric edges or attaching lace or rubber tape.
S	5	Securing Program	For automatic securing at the start of the seam with forward and reverse stitches.
---	6	Triple Straight Stitch	For reinforced seams on heavy fabrics and decorative effects.
W	7	Triple Zig zag	For durable seams on strong fabrics, visible hems and decorative seams.
X	8	Honeycomb Stitch	For stretch fabrics and hems, including with rubber threads.
W	9	Blind Stitch	For blind hems on most fabric types and for shell edging on soft jerseys and fine fabric.
W	10	Double Overlock	For simultaneously sewing together and finishing elastic fabrics.
W	11	Superstretch Stitch	For highly stretch open seams.

	12	Gathering Stitch	For gathering with rubber threads and for flat joining seams on medium-weight fabrics.
	13	Stretch Overlock	For simultaneously sewing together and finishing elastic fabrics, as well as for flat joining seams.
	14	Tricot Stitch	For visible hems and seams in lingerie and sweaters and for mending tricot fabric.
	15	Universal Stitch	For flat joining seams, visible hems and decorative seams in strong fabrics such as felt and leather and for attaching rubber tape.
	16	Sewn-out Zigzag	For finishing and reinforcing fabric edges, for sewing on rubber tape and for decorative seams.
	17	Lycra Stitch	For flat joining seams, visible hems on Lycra fabric and for stitching over seams in foundation garments.
	18	Stretch Stitch	For stretchable seams and hems in woven and knitted fabrics.
	19	Reinforced Overlock	For overlock seams or flat joining seams on medium-weight knit fabrics and toweling.
	20	Knit Overlock	For stretchable seams and hems in woven and knitted fabric, for sewing and finishing.
	21	Basting stitch	For tacking seams and hems and for quilting projects.
	22	Simple Darning Program	For automatic darning in fine to strong fabrics.
	23	Reinforced Darning Program	For automatic darning in strong materials.
	24	Bartack Program	For reinforcing pocket openings, buttonhole bars and for sewing belt loops.
	25	Bartack Program	For reinforcing pocket openings, sewing belt loops and securing seam ends.
	26	Large Fly Stitch	For reinforcing pocket openings, zippers and slits in medium-weight to thick fabrics.



	27	Small Fly Stitch	For reinforcing pocket openings, zippers and slits in fine to medium-weight fabrics.
	29	Narrow Blind Stitch	For blind hems and shell edging in light, fine and soft fabrics.
	31	Triple straight stitch with long stitch	For durable seams in strong fabrics, e.g. visible and decorative seams.
	32	Single Straight Stitch	As a connecting stitch in a combination for one straight stitch.
	33	Three Single Straight Stitches	As connecting stitches in a combination for three individual straight stitches.
	34	Darning Stitch	For darning together with the function "Quick Reverse".

6.2 Sewing Straight Stitch

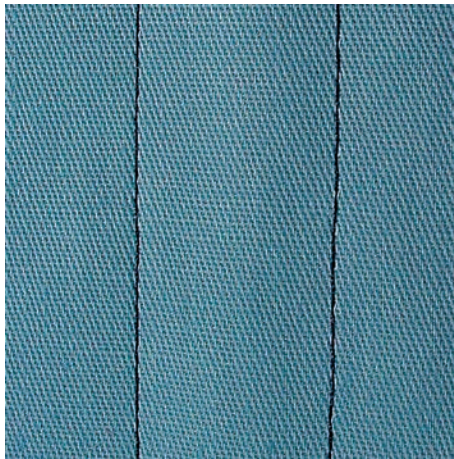

Adjust the stitch length for the sewing project, e.g. a long stitch for denim (approx. 3 – 4 mm) and a short stitch for delicate fabric (approx. 2 – 2.5 mm). Adjust the stitch length depending on the thread thickness, e.g. a long stitch (approx. 3 – 5 mm) for top-stitching with gimp.

Prerequisite:

- The Reverse Pattern Foot #1C/1D is fitted.



- > Tap «Practical Stitches».
- > Select Straight Stitch No. 1.



- > Open the zipper length.
- > Baste the zipper under the fabric so that the fabric folded edges meet over the center of the zipper.
- > Open the zipper a few centimeters.
- > Fit the Zipper Foot #4D.
- > Move the needle position to the right.
- > Use the Free Hand System to raise the presser foot and to position the sewing project.
- > Start sewing from top left.
- > Guide the foot so that the needle stitches along the zipper coils.
- > Stop in front of the zipper pull with needle position down.
- > Raise the presser foot.
- > Close the zipper.
- > Continue to sew and stop in front of the base of the zipper with needle position down.
- > Raise the presser foot and turn the sewing project.
- > Sew across the other side of the zipper and stop with needle position down.
- > Raise the presser foot and turn the sewing project.
- > Sew the second side from bottom to top.

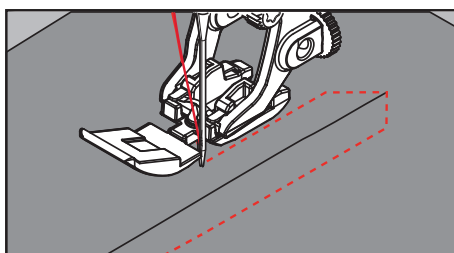

6.5 Sewing Both Sides of the Zipper from Bottom to Top

For fabrics with pile, such as velvet, it is recommended to sew in the zipper on both sides from bottom to top.



When the fabric is firm or densely woven, it is recommended to use a needle with the size 90 – 100. This results in an even stitch formation.



- > Fit the Reverse Pattern Foot #1C.
- > Tap «Practical Stitches».
- > Select Straight Stitch No. 1.
- > Sew the seam up to where the zipper starts.
- > Sew the securing stitches.
- > Close the zipper length with long stitches.
- > Finish the seam allowances.
- > Iron the seam.
- > Open the zipper length.
- > Baste the zipper under the fabric so that the fabric folded edges meet over the center of the zipper.
- > Fit the Zipper Foot #4D.
- > Move the needle position to the right.
- > Use the Free Hand System to raise the presser foot and to position the sewing project.
- > Start sewing in the center of the seam at the end of the zipper.
- > Sew diagonally along the edge of the zipper coils.
- > Sew the first side (1) from bottom to top.
- > Stop in front of the zipper pull with needle position down.
- > Raise the presser foot.
- > Open the zipper as far as behind the presser foot.
- > Lower the presser foot and continue sewing.
- > Move the needle position to the left.



6.8 Manual Darning

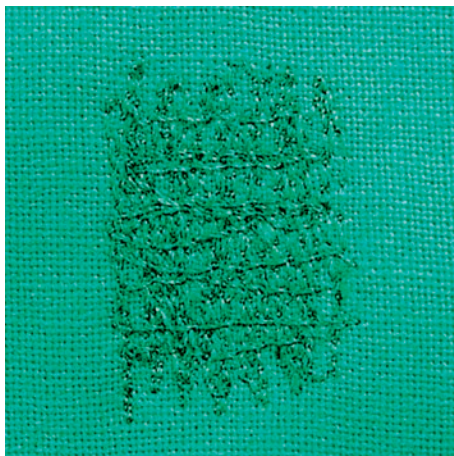

Used for darning holes or worn areas in all fabric types.

If the thread is lying on top and a poor stitch formation results, slow down the movement of the sewing project. If there are knots on the wrong side of the fabric, move the sewing project faster. When the thread breaks, guide the sewing project more consistently.



- > Fit the Darning Foot #9.
- > Tap «Practical Stitches».
- > Select Straight Stitch No. 1.
- > Lower the feed dog.
- > Attach the Slide-on Freearm Extension Table.
- > Hoop the sewing project in the round embroidery hoop (optional accessory).
 - The darning area stays evenly taut and cannot be distorted.
- > Sew from the left to the right, guide the fabric evenly by hand without using pressure.
- > Move in curves when changing the direction to avoid holes and thread breakage.
- > Work the edges in irregular lengths so that the thread is better spread over the fabric.

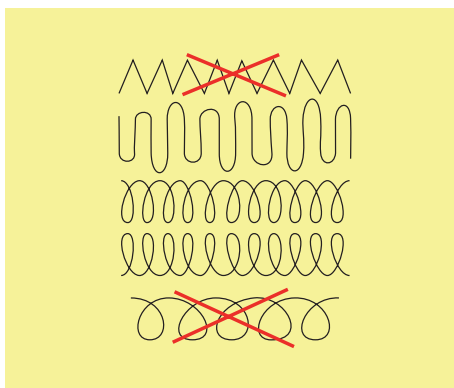

- > Sew the first rows not too close together and beyond the worn area.
- > Sew the rows in irregular lengths.

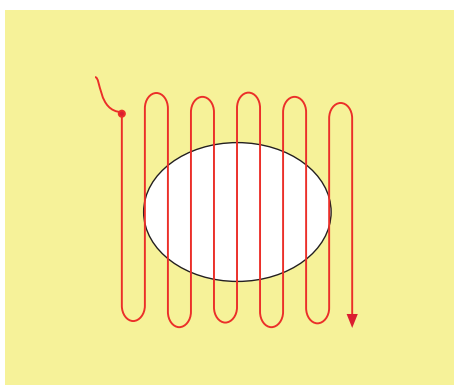

- > Start sewing top left.
- > Sew the first row.
- > Stop the machine.
- U > Push the button «Quick Reverse».
 - The length is programmed.
- > Finish sewing the Darning Program.
 - The machine stops automatically.

6.10 Reinforced Darning, Automatic



The Reinforced Darning Program No. 23 is particularly suitable for quick darning of worn areas or tears. The Reinforced Darning Program No. 23 replaces the longitudinal threads in all fabrics.



If the Darning Program does not cover the whole worn or damaged area, it is recommended to reposition the work and sew the Darning Program again. The length is programmed and can be repeated as often as desired.



- > Fit the Buttonhole Foot with Slide #3A.
- > Tap «Practical Stitches».
- > Select Reinforced Darning Program No. 23.
- > Hoop light-weight materials in the round embroidery hoop (optional accessory).
 - The darning area stays evenly taut and cannot be distorted.
- > Start sewing top left.
- > Sew the first row.
- > Stop the machine.
- U > Push the button «Quick Reverse».
 - The darning length is programmed.
- > Finish sewing the Darning Program.
 - The machine stops automatically.



6.13 Sewing Double Overlock



A double overlock seam is suitable for loose knits and cross seams in knits. When working with jersey, a jersey needle should be used to prevent damaging the knit fabric. When sewing stretch materials, use a stretch needle.

- > Fit the Reverse Pattern Foot #1C or Overlock Foot #2A.
- > Tap «Practical Stitches».
- > Select Double Overlock No. 10.



6.14 Narrow Edgestitching

- > Fit the Blindstitch Foot #5 or Edgestitch Foot #10/10C/10D.
- > Tap «Practical Stitches».
- > Select Straight Stitch No. 1.
- > Place the edge against the left-hand guide of the Blindstitch Foot.
- > Select the left-hand needle position at the desired distance to the edge.

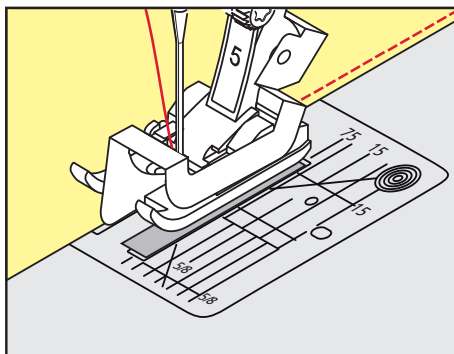

6.15 Wide Edgestitching

- > Fit the Reverse Pattern Foot #1C.
- > Tap «Practical Stitches».
- > Select Straight Stitch No. 1.
- > Guide the edge along the presser foot or at a distance of 1 – 2.5 cm along the marks on the stitch plate.



- > Select the needle position at the desired distance to the edge.

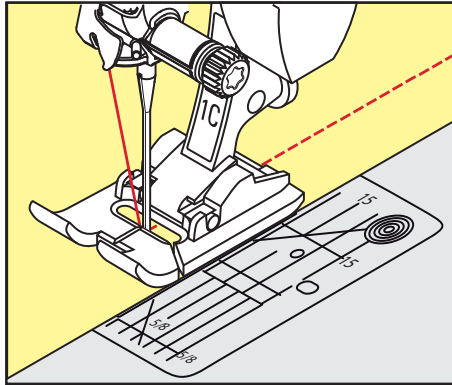

6.16 Edgestitching using the seam guide

When sewing parallel wider lines, it is recommended to guide the seam guide along the sewn of lines.

- > Fit the Reverse Pattern Foot #1C.
- > Tap «Practical Stitches».
- > Select Straight Stitch No. 1.
- > Loosen the screw on the back of the presser foot.
- > Insert the seam guide into the hole in the presser foot.
- > Adjust the width as required.
- > Tighten the screw.
- > Guide the folded edge along the seam guide.

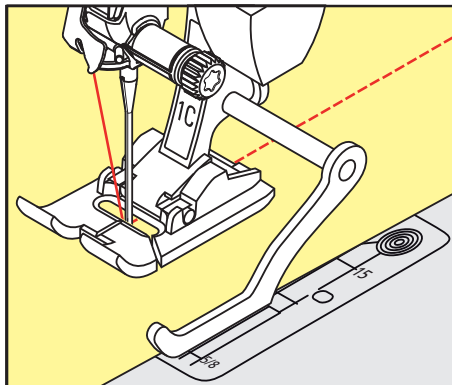

6.17 Sewing Hem Edges

When using the Blindstitch Foot #5, it is recommended to set the needle position to the far left or right. With the Reverse Pattern Foot #1C and Edgestitch Foot #10/10C/10D all needle positions are possible.

- > Fit the Blindstitch Foot #5 or the Reverse Pattern Foot #1C or the Edgestitch Foot #10/10C/10D.
- > Tap «Practical Stitches».
- > Select Straight Stitch No. 1.
- > Place the inner upper hem edge against the guide of the Blindstitch Foot on the right.



- > Select the needle position to the far right in order to sew along the upper edge.

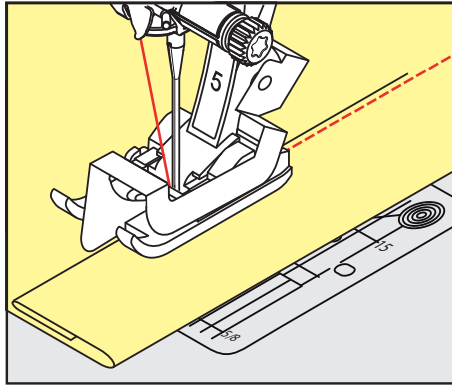

6.18 Sewing Blind Hems

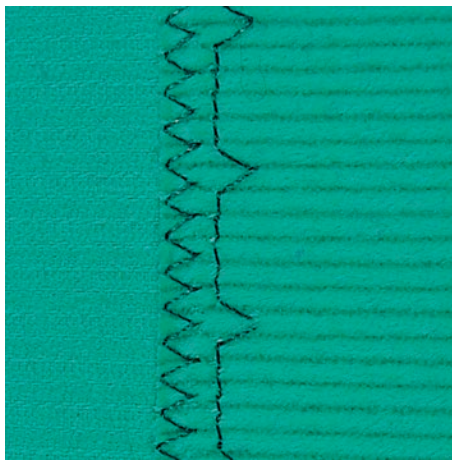

For invisible hems in medium to heavy weight cotton, wool and blended materials.

Prerequisite:

- The fabric edges are finished.
- > Fit the Blindstitch Foot #5.
- > Tap «Practical Stitches».
- > Select Blind Stitch No. 9.
- > Fold the fabric so that the finished fabric edge is on the right side.
- > Place the fabric under the presser foot and move the folded edge against the metal guide on the presser foot.
- > Guide the folded edge evenly along the metal guide of the presser foot to sew the stitches evenly deep.
 - Make sure that the needle only pierces the edge of the fold.
- > After sewing about 10 cm, check both sides of the fabric and adjust the width again if necessary.

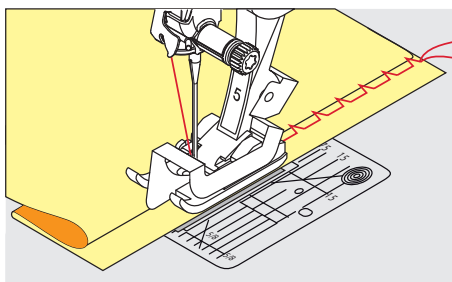

6.19 Sewing Visible Hems



The visible hem is particularly suitable for elastic seams in tricot made of cotton, wool, synthetic and mixed fibers.

- > Fit the Reverse Pattern Foot #1C/1D.
- > Tap «Practical Stitches».
- > Select Tricot Stitch No. 14.
- > Iron the hem and baste if necessary.
- > Reduce the presser foot pressure if necessary.
- > Sew the hem in the desired depth on the right side of the fabric.
- > Trim off the remaining fabric on the wrong side of the fabric.

6.20 Sewing Flat Joining Seams

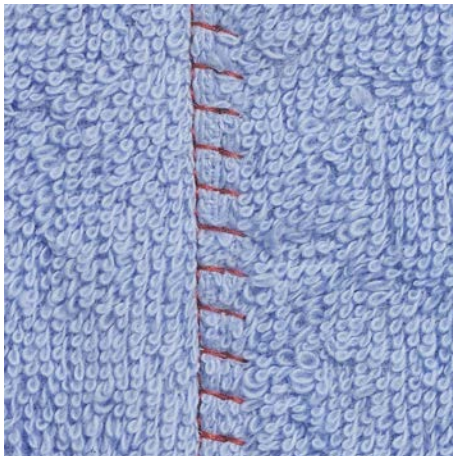

The flat joining seam is especially suitable for long-pile or thick materials such as terrycloth, felt or leather.

- > Fit the Reverse Pattern Foot #1C.
- > Tap «Practical Stitches».
- > Select Stretch Overlock No. 13.
- > Overlap the fabric edges.
- > Sew along the fabric edge.
- > To get a very flat, durable seam, make sure the needle stitches right over the top edge of the fabric into the bottom fabric.

7 Decorative Stitches











7.1 Overview Decorative Stitches





Easier or more difficult decorative stitches come into their own depending on the type of fabric.

- Decorative stitches which are programmed with single straight stitches are particularly appropriate for lightweight materials, e. g. Decorative StitchNo. 101
- Decorative stitches which are programmed with triple straight stitches or with a few satin stitches are particularly appropriate for medium-weight materials, e. g. Decorative Stitch No. 107.
- Decorative stitches which are programmed with satin stitches are particularly appropriate for heavyweight materials, e. g. Decorative StitchNo. 401

For a perfect stitch formation, it is of advantage to use the same thread color for upper and bobbin thread and a stabilizer. With pile or longfiber materials, it is recommended to use an additional water-soluble stabilizer, which can be easily removed after sewing, on the right side of the fabric.



Decorative Stitch	Category	Name
	Category 100	Nature Stitches
	Category 200	Nature Stitches with Sideways Motion
	Category 300	Cross Stitches
	Category 400	Satin Stitches
	Category 500	Satin Stitches with Sideways Motion
	Category 600	Geometric Stitches
	Category 700	Heirloom Stitches
	Category 800	Heirloom Stitches with Sideways Motion
	Category 900	Children Stitches
	Category 1000	Children Stitches with Sideways Motion

Decorative Stitch	Category	Name
	Category 1200	Filigree Stitches with Sideways Motion
	Category 1400	Tapering
	Category 1500	Skyline Stitches (Special Stitches)
	Category 1600	Quilt Stitches Sideways Motion
	Category 1700	International

7.2 Bobbin-Play



The bobbin can be filled with different thread material. For free-motion stitching to add texture. This method is similar to “normal” free-motion sewing, but is done on the **wrong** side of the fabric.

Reinforce the area to be sewn with embroidery stabilizer. The design can be drawn on the wrong side of the fabric. You can also draw the design on the front side of the fabric. The lines can be followed with a freely guided straight stitch using polyester, cotton or rayon thread. The rows of stitching are visible on the wrong side of the fabric, and they serve as guidelines for the bobbin-thread sewing.

The BSR function can be used for bobbin-thread sewing. We recommend guiding your project evenly under the needle at a consistent speed, following the lines of the design. The stabilizer must be removed after sewing.

Sew a sample first to check what the result looks like on the wrong side of the fabric.

Not all decorative stitches are suitable for this technique. Simple decorative stitches provide best results. Avoid compact stitch types and satin stitches.

NOTICE

Inappropriate bobbin case is used

Damage of the bobbin case.

> Use the special bobbinwork case (optional accessory).





> Fit the Open Embroidery Foot #20C/20D.

> Tap «Decorative Stitches».





> Select an appropriate decorative stitch.

> Turn the «Upper Multifunction Knob» and the «Lower Multi-function Knob» to set the stitch length and stitch width so that a beautiful stitch formation can be achieved even when sewing with thick thread.

-  > Tap «i-Dialog».
-  > Tap «Long Stitch».
 - Every second stitch is sewn.
-  > To adjust the upper thread tension, tap «Upper Thread Tension».

7.3 Altering the stitch density

With certain decorative stitches (e. g. No. 401) the stitch density can be altered. If the stitch density is increased, the stitch distance is enlarged. If the stitch density is decreased, the stitch distance is shortened. The programmed length of the stitch pattern is not affected.

-  > Select the decorative stitch.
-  > Tap «i-Dialog».
-  > Tap «Altering the Pattern Length/Stitch Density».
-  > Set the stitch density (1).



7.4 Tapering

Overview Tapering



- | | |
|---|--|
| 1 «Programming the Length of Section 2» | 6 «Manual Tapering» |
| 2 «Pattern Repeat» | 7 «Selecting Kind of Tapering» |
| 3 «Adjusting Lengths» | 8 «Back Stepping» |
| 4 «Mirror Image Left/Right» | 9 «Saving Settings of Stitch Patterns» |
| 5 «Balance» | 10 «Reset Stitch Pattern» |

Altering points of a stitch pattern

Tapering is a technique in which the stitch patterns come to a point at the beginning and at the end. A choice of 4 preset stitch pattern tips is available. In addition, the tips of the stitch pattern can also be determined individually.



- > Tap «Decorative Stitches».
- > Select a stitch pattern of the Category 1400.



- > Tap «i-Dialog».



- > Tap «Selecting Kind of Tapering».
- > Select the desired point of the stitch pattern in the right portion of the display.



- > To individualize the tips of the stitch pattern, tap «Setting the Stitch Pattern Tips».
- > To alter the tips of the stitch pattern, tap «Minus» in the upper right area of the display or «Plus».
- > To alter the length of the stitch pattern tips, tap «Minus» in the lower right area of the display or «Plus».



Sewing tapering

Alterations to the selected stitch pattern are saved automatically. In Manual Mode, the alterations are discarded after the stitch pattern is selected again.



- > Tap «Decorative Stitches».
- > Select a stitch pattern of the Category 1400.



- > Tap «i-Dialog».



- > In order to not save alterations to the stitch pattern, tap «Manual Tapering».



- > In order to save alterations to the stitch pattern automatically, tap «Programming the Length of Section 2».

- > To start sewing, press the button «Start/Stop» or operate the foot control.



- > Press the button «Quick Reverse» as soon as the desired length in the center section of the tapering is reached.
 - The machine sews the whole stitch pattern and stops automatically.

Sewing tapering automatically

- > Tap «Decorative Stitches».
- > Select a stitch pattern of the Category 1400.
- > Tap «i-Dialog».
- > Tap «Adjusting Lengths».
- > To adjust the length, turn the «Upper Multi-function Knob» or «Lower Multi-function Knob».
- > To start sewing, press the button «Start/Stop» or operate the foot control.
 - The machine sews the whole stitch pattern and stops automatically.

7.5 Sewing Cross Stitches

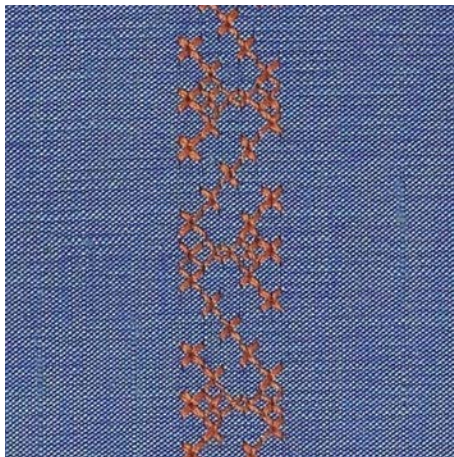

Cross stitch embroidery is a traditional technique and an addition to the other decorative stitches. If the cross stitches are sewn on fabrics with a linen structure, they look as if they were hand-stitched. When cross stitches are sewn with embroidery yarn, the stitch pattern appears fuller. Cross stitches are particularly used for home furnishing, trimmings on garments and embellishing in general. As every following line refers to the first row, it is important to stitch the first row in a straight line.

- > Fit the Reverse Pattern Foot #1C/1D or Open Embroidery Foot #20C/20D.
- > Select a cross stitch of the Category 300 and combine it as desired.
- > Stitch the first row using the seam guide to sew a straight line.
- > Stitch the second row next to the first at a distance of one presser foot's width or using the seam guide.



7.6 Pintucks



Pintucks



Pintucks are narrow stitched folds, which are normally sewn on the fabric before cutting out the pieces for the garment or the sewing project. They are suitable for embellishing or in combination with other heirloom embroidery techniques. The use of Pintuck Feet can simplify this technique considerably. The technique reduces the size of the fabric piece. It is always advisable to plan in sufficient fabric.

Overview Pintuck Feet

Pintuck Foot	Number	Description
	# 30 (optional accessory)	3 grooves For heavy-weight fabrics. In combination with the 4 mm twin needle
	# 31 (optional accessory)	5 grooves For heavy to medium-weight fabrics. In combination with the 3 mm twin needle
	# 32 (optional accessory)	7 grooves For light to medium-weight fabrics. In combination with the 2 mm twin needle

Pintuck Foot	Number	Description
	# 33 (optional accessory)	9 grooves For very light fabrics (without extra cord). In combination with the 1 or 1.6 mm twin needle
	# 46C (optional accessory)	5 grooves In combination with the 1.6 – 2.5 mm twin needle For very light to medium-weight fabrics.

Working with Cord

The pintucks look more distinctive and relief-like when they are sewn with a supplementary cord. Choose a cord that fits well into the grooves of the respective foot. The cord must be colorfast and shrink-proof.

- > Switch off the machine.
- > Remove the needle.
- > Remove the presser foot.
- > Remove the stitch plate.
- > Open the hook cover.
- > Pull the cord through the hook opening from the bottom and through the opening of the stitch plate.
- > Replace the stitch plate.
- > Close the hook cover.
- > Make sure that the cord slides through the thread slot of the bobbin cover.

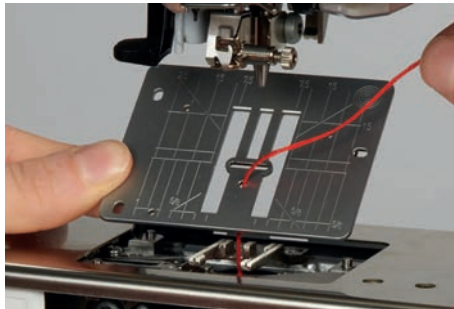

- > Place the spool on the knee lifter.



- > Check that the cord runs smoothly.
- > If the thread doesn't glide smoothly at the hook cover, leave the hook cover open.

8 Alphabets and Monograms

8.1 Overview Alphabets

Block, Outline, and Script lettering, as well as Cyrillic can be sewn in two different sizes. Monograms can be sewn in three different sizes. Block, Outline, and Script lettering, as well as Cyrillic can also be sewn in lower-case letters.

For a perfect stitch formation, it is recommended to use the same thread color for upper and bobbin threads. The fabric can be reinforced with embroidery stabilizer on the wrong side. When working with pile or napped fabrics, e.g. toweling, use an additional, water-soluble stabilizer on the right side of the fabric.



Stitch Pattern	Name
ABCabc	Block alphabet
ABCabc	Double-Block
<i>ABCabc</i>	Script (Italics)
ABCabc	Comic lettering
АБВабв	Cyrillic
あいう	Hiragana
アイウ	Katakana
<i>ABC</i>	Monograms 30/20/15 mm

8.2 Creating lettering







When sewing Sideways Motion patterns, for example monograms, it is recommended to use the Sideways-motion Foot #40C. Sewing a test sample with the thread, the actual fabric and stabilizer you intend to use is recommended. Make sure that the fabric is fed evenly and lightly, ensuring that it cannot push against or catch on anything. The fabric shouldn't be pulled, pushed or held back.



- > Tap «Alphabets».
- > Select the font.

- > To create a combination, tap «Combination Mode/Single Mode».
- > To open the extended Enter Mode, tap «Increasing/Decreasing the Display Size» (1).





- > Select the letters.
-  > To use upper-case letters, tap «Upper Case Characters» (standard setting).
-  > To use lower-case letters, tap «Lower Case Characters».
-  > To use figures and mathematical symbols, tap «Numbers and Mathematical Characters».
-  > To use special characters, tap «Special Characters».



-  > To delete individual syllables of the entered text, tap «Deleting».
- > To close the extended Enter Mode, tap «Increasing/Decreasing the Display Size» again.

8.3 Altering font size



Block, outline, script, comic, and Cyrillic fonts can be scaled down in Single Mode.

-  > Tap «Alphabets».
- > Select the font.
- > Select the letters.
-  > Tap «i-Dialog».
-  > To reduce the font size, tap «Alter Font Size».
- > To scale up the font size to 9 mm, tap «Alter Font Size» again.

8.4 Altering size of monogram

The font size is preset to 30 mm. The letters can be scaled down to 20 mm or 15 mm.

Prerequisite:

- A single letter is selected.
-  > Tap «i-Dialog».
-  > To reduce the font size to 20 mm, tap «Altering Size of Monogram».
- > To reduce the font size to 15 mm, tap «Altering Size of Monogram» again.
- > To scale up the font size to 30 mm, tap «Altering Size of Monogram» again.





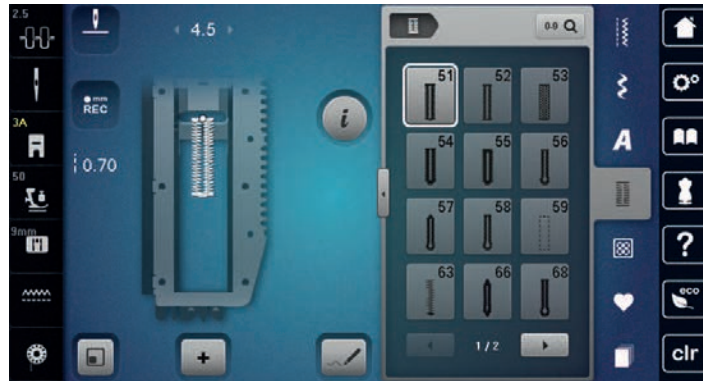

9 Buttonholes

9.1 Overview Buttonholes

To be able to create the right buttonhole for every button, every purpose and also for every garment, the BERNINA 790 PLUS comes with an extensive collection of buttonholes. The corresponding button can be sewn on automatically. Eyelets can also be sewn.



Stitch patterns	Stitch number	Name	Description
	51	Standard Buttonhole	For light to medium-weight fabrics. e.g. blouses, dresses and bed linen.
	52	Narrow Standard Buttonhole	For light to medium-weight fabrics, e.g. blouses, dresses, children's and baby clothes, crafts.
	53	Stretch Buttonhole	For all elastic fabrics.
	54	Round Buttonhole with Normal Bartack	For medium-weight to heavy fabrics. e.g. dresses, jackets, coats and rainwear.
	55	Round Buttonhole with Horizontal Bartack	For medium-weight to heavy fabrics, with a reinforced bar, e.g. dresses, jackets, coats and rainwear.
	56	Keyhole Buttonhole	For heavy, non-stretch fabrics, e.g. jackets, coats and leisurewear.
	57	Keyhole Buttonhole with Pointed Bartack	For stronger, non-stretch fabrics, e.g. jackets, coats, jeans and leisurewear.
	58	Keyhole Buttonhole with Horizontal Bartack	For strong, non-stretch fabrics, e.g. jackets, coats and leisurewear.
	59	Straight Stitch Buttonhole	For staystitching and reinforcing buttonholes and as button hole edging, especially for buttonholes in leather and imitation leather.
	60	Button Sew-on Program	Sews buttons with 2 or 4 holes.

	61	Eyelet with Small Zigzag	Openings for cords or narrow ribbons and for decorative work.
	62	Eyelet with Straight Stitch	Openings for cords or narrow ribbons and for decorative work.
	63	Heirloom Buttonhole	For handlook stitching effects on clothes and handicrafts on light to medium-weight fabrics.
	66	Narrow buttonhole with double pointed bartack	For decorative buttonholes in medium-weight fabrics, e.g. dresses and jackets.
	68	Decorative keyhole buttonhole with horizontal bartack	For stronger, non-stretch fabrics, e.g. jackets, coats and leisurewear.
	69	Decorative Buttonhole with Double Pointed Bartack	For decorative buttonholes in firmer, non-elastic fabrics.

9.2 Making Use of the Height Compensation Tool

When a buttonhole is to be sewn at right angles to the project edge, it is recommend to use the height compensation plates (optional accessory).

- > Place the plates from the back between the sewing project and the bottom of the slide to the thick part of the sewing project.

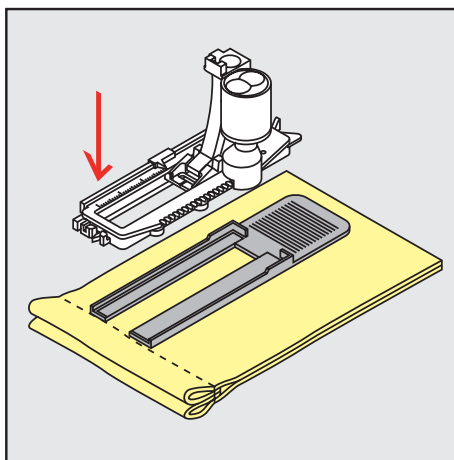

- > Lower the presser foot.

9.3 Using the Compensation Plate

For sewing a buttonhole in problematic fabrics, it is recommended to use the Height Compensation Tool (optional accessory). The Height Compensation Tool can be used in combination with the Buttonhole Foot with Slide #3A.

- > Insert the compensation plate carefully from the side.

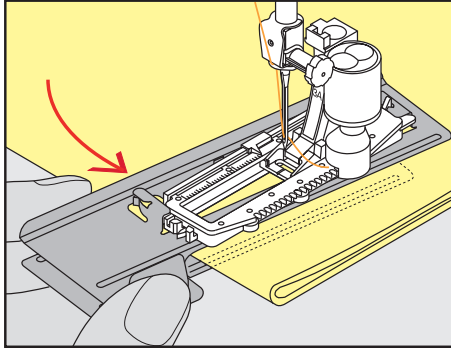

9.4 Marking Buttonholes

- > For the buttonholes to be sewn manually, mark the position and the length on the fabric using chalk or a water-soluble pen.

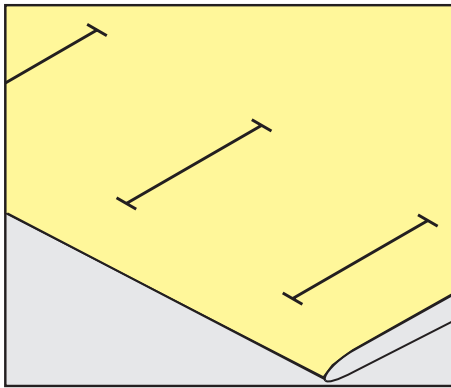

- > For the buttonholes to be sewn automatically, mark the complete length of 1 buttonhole on the fabric using chalk or a water-soluble pen. For any subsequent buttonholes mark the starting point.

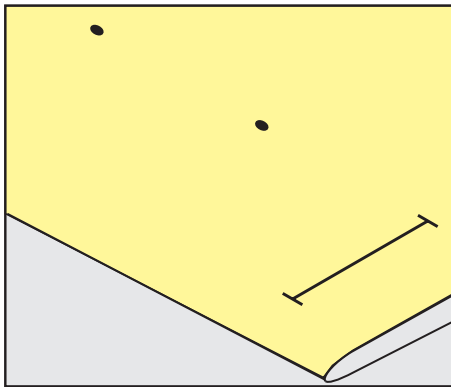

- > For keyhole and round buttonholes mark the length of the bead with chalk or a water-soluble pen on the fabric. For any subsequent buttonholes mark the starting point. The length of the keyhole is sewn additionally.

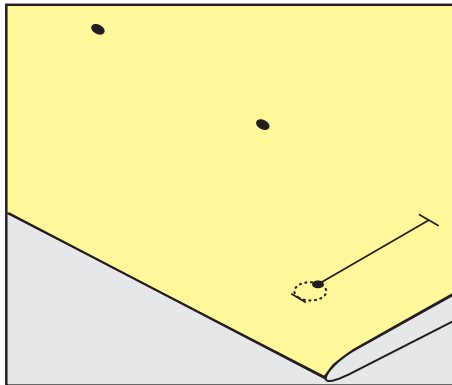

9.5 Cord

Using Cord with the Buttonhole Foot with Slide #3A

The additional cord reinforces and embellishes the buttonhole and is particularly suitable for the Buttonhole No. 51. Ideal cords are Perle cotton No. 8, strong hand-sewing thread and fine crochet yarn. It is recommended to not hold the cord while sewing.

Prerequisite:

- The Buttonhole Foot with Slide #3A is fitted and raised.
- > Insert the needle at the beginning of the buttonhole.
- > Guide the cord on the right side under the Buttonhole Foot with Slide.
- > Hook the cord over the pin at the back of the Buttonhole Foot with Slide.

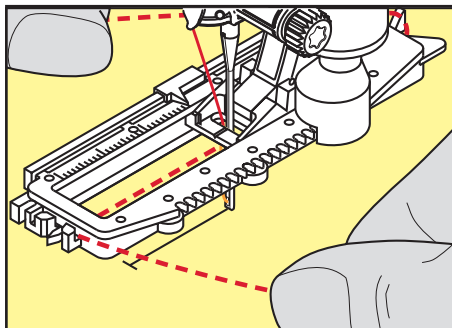

- > Pull the cord on the left side under the Buttonhole Foot with Slide to the front.

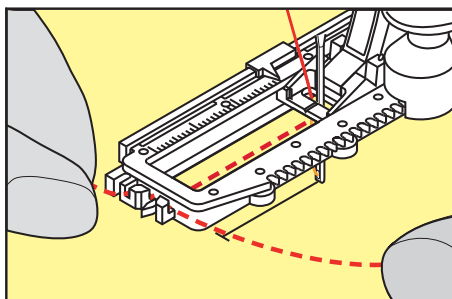

- > Pull the cord ends into the slits.
- > Lower the Buttonhole Foot with Slide.
- > Sew the buttonhole in the usual manner.
- > Pull the cord loop until the loop disappears in the bartack.

- > Pull the ends of the cord through to the wrong side of the fabric (using a hand sewing needle) and knot or secure them with stitches.

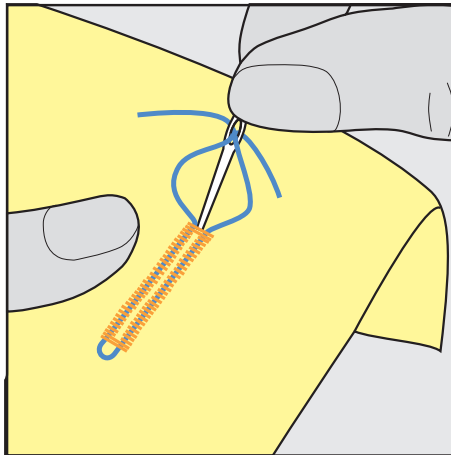

Using cord with the Buttonhole Foot #3C

Prerequisite:

- The Buttonhole Foot #3C is fitted and raised.
- > Insert the needle at the beginning of the buttonhole.
- > Hook the cord over the center pin at the front of the Buttonhole Foot.

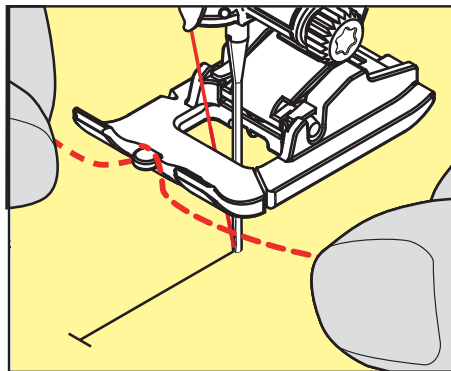

- > Pull both cords ends under the Buttonhole Foot to the back and place each a cord into a groove of the sole.

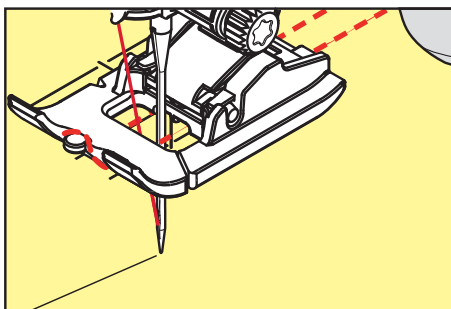

- > Lower the Buttonhole Foot.
- > Sew the buttonhole in the usual manner.
- > Pull the cord loop until the loop disappears in the bartack.

- > Pull the cord ends with the sewing needle to the back and knot or secure them.

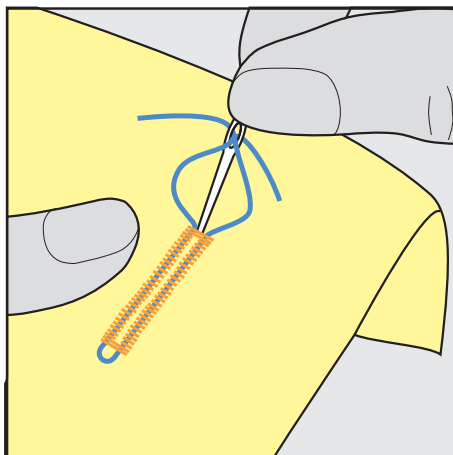

9.6 Sewing a Test Sample

Always sew a test sample of the buttonhole on the same fabric: It is recommended to use the same stabilizer and to select the same buttonhole. The test sample should also be sewn in the respective direction. By sewing a test sample the settings can be adjusted until the sewing result is satisfying.

It is worth underlaying the buttonholes with the Straight Stitch Buttonhole No. 59 when working with soft loosely woven materials and for buttonholes which are severely strained. This is also recommended to reinforce buttonholes in leather, vinyl or felt.

Alterations of the Balance when sewing a manual standard buttonhole as well as the Keyhole and the Round Buttonhole affect both beads in the same way. With the manual keyhole or round buttonhole, the alterations affect both sides in the opposite way.

If the Stitch Counter function is used, and alterations are made concerning the Balance, the alterations affect both buttonhole beads differently.



- > Tap «Buttonholes».
- > Select the buttonhole.
- > Select and fit the desired presser foot.
- > Place the fabric under the presser foot and lower the presser foot.
- > Press the foot control carefully and start sewing. Guide the fabric slightly.
- > Check the Balance while sewing and adjust if necessary.
- > Check the test sample and make further amendments if necessary.

9.7 Determining the Buttonhole Slit Width

The width of the buttonhole slit can be adjusted between 0.1 – 2.0 mm before sewing.



- > Tap «Buttonholes».
- > Select the buttonhole.



- > Tap «i-Dialog».



- > Tap «Buttonhole Slit Width».
- > To adjust the desired width of the buttonhole slit, turn the Upper Multi-function Knob or the «Lower Multi-function Knob».

9.8 Determining the Buttonhole Length with the Buttonhole Foot with Slide #3A



The button can be centered in the yellow circle in the lower portion of the display. The yellow circle can be enlarged or downsized with the «Multifunctional knobs up/down» and the diameter of the button can be determined in this way.

9.10 Sewing a buttonhole automatically

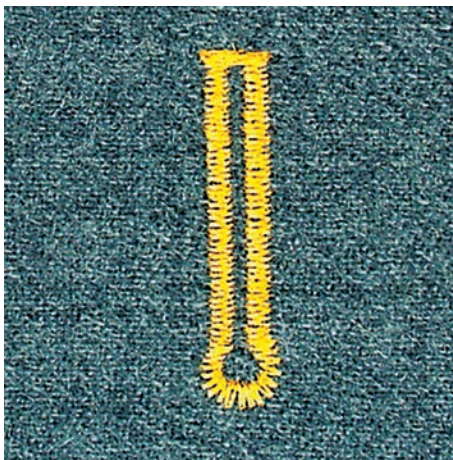
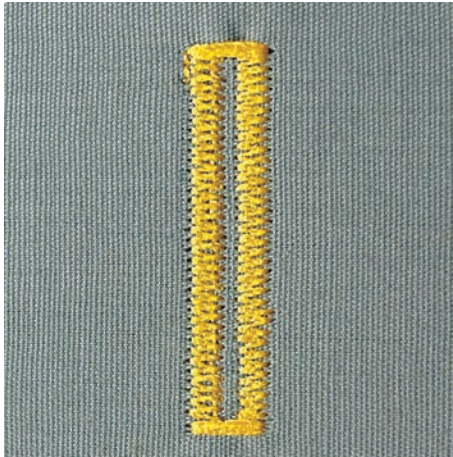

When the Buttonhole Foot with Slide #3A is used, the length of the buttonhole is measured automatically by the lens on the presser foot. The buttonhole will be exactly duplicated and the machine switches to the next step automatically when the maximum length is reached. The Buttonhole Foot with Slide #3A is suitable for buttonholes at a length of 4 – 31 mm, depending on the buttonhole type. The Buttonhole Foot with Slide #3A must lie perfectly flat on the fabric so that the length can be measured accurately. Programmed buttonholes are all at the same length and of the same nice look.

Prerequisite:

- The Buttonhole Foot with Slide #3A is fitted.



- > Tap «Buttonholes».
- > Select the Buttonhole No. 51 – 53 or 54 – 58 or No. 66, 68 or 69.
- > Sew the desired length of the buttonhole.



- > To program the length, push the button «Quick Reverse».



- > Push the button «Start/Stop» or press the foot control.
 - The machine finishes the buttonhole automatically. All subsequent buttonholes are sewn at the same length.

9.11 Programming the Heirloom Buttonhole

Prerequisite:

- The Buttonhole Foot with Slide #3A is fitted.



- > Tap «Buttonholes».
- > Select Heirloom Buttonhole No. 63.
- > Sew the desired length of the buttonhole.

- > To program the length, push the button «Quick Reverse».
 - The machine finishes the buttonhole automatically. All subsequent buttonholes are sewn at the same length.

9.12 Sewing the manual 7-step buttonhole

The length of the buttonhole is determined manually when sewing. The bartack, eye and securing stitches are preprogrammed. The individual steps can be selected by scrolling with the arrow icons, by direct selection or by pressing the button «Quick Reverse».

Prerequisite:

- The Buttonhole Foot with Slide #3C (optional accessory) is fitted.



- > Tap «Buttonholes».
- > Select Standard Buttonhole No. 51.



- > Tap «i-Dialog».



- > Tap «Manual Length Adjustment».
 - Step 1 is activated in the display to start the buttonhole.
- > Sew the desired length of the buttonhole.
 - Step 2 becomes active when sewing starts.



- > Stop when the required length of the buttonhole or the length marking is reached.
- > Step 3 appears by tapping «Scroll Down».
 - The machine sews straight stitches in reverse.
- > Stop the machine at the level of the first stitch at the start of the buttonhole.
- > Step 4 appears by tapping «Scroll Down».
 - The machine sews the upper bartack and stops automatically.
- > Step 5 appears by tapping «Scroll Down».
 - The machine sews the second bead.
- > Stop the machine at the level of the last stitch of the first bead.
- > Step 6 appears by tapping «Scroll Down».
 - The machine sews the lower bartack and stops automatically.
- > Step 7 appears by tapping «Scroll Down».
 - The machine secures and stops automatically.

9.13 Sewing the manual 5-step buttonhole

The length of the buttonhole is determined manually when sewing. The bartack, eye and securing stitches are preprogrammed. The individual steps can be selected by scrolling with the arrow icons, by direct selection or by pressing the button «Quick Reverse».

Prerequisite:

- The Buttonhole Foot with Slide #3C (optional accessory) is fitted.

- > Tap «Buttonholes».
- > Select Round Buttonhole with Normal Bartack No. 54.
- > Tap «i-Dialog».
- > Tap «Manual Length Adjustment».
 - Step 1 is activated in the display to start the buttonhole.
- > Sew the desired length of the buttonhole.
 - Step 2 is activated.



- > Stop when the required length of the bead or the length marking is reached.
- > Step 3 appears by tapping «Scroll Down».
- > The machine sews the curve or the eye and stops automatically.
- > Step 4 appears by tapping «Scroll Down».
 - The machine sews the second bead in reverse.
- > Stop the machine at the level of the first stitch where the buttonhole begins.
- > Step 5 appears by tapping «Scroll Down».
 - The machine sews the upper bartack and secures automatically.

9.14 Cutting the Buttonhole Open with the Seam Ripper

- > Place a pin in each end of the buttonhole to avoid accidental cutting into ends of buttonhole.
- > Cut the buttonhole from both ends to the middle.

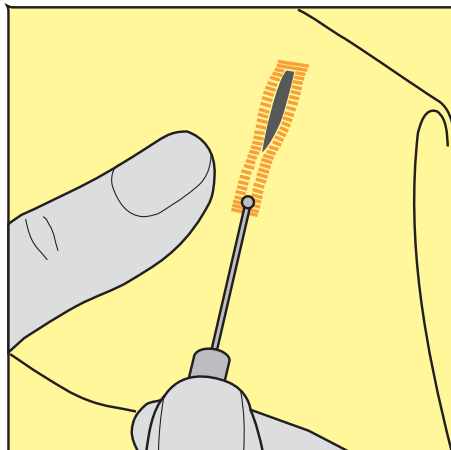

9.15 Cutting Open Buttonholes with the Buttonhole Cutter (Optional Accessory)

- > Place the fabric on an appropriate wood.

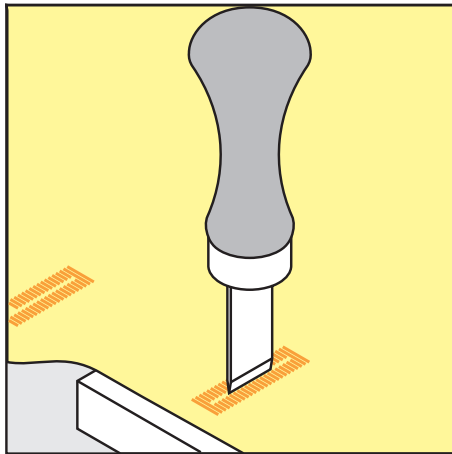

- > Position the cutter in the center of the buttonhole.
- > Press down on the cutter with your hand.

9.16 Sewing on a Button

The Button sew-on Program can be used to sew on buttons with two or four holes, press studs or snap fasteners.

Recommended sewing program: Button Sew-on Program No. 60

Recommended presser foot : Button Sew-On Foot #18

Alternative presser feet:

- Reverse Pattern Foot #1/1C
- Darning Foot #9
- Reverse Pattern Foot with Clear Sole #34/34C

Adjusting the Thread Shank

For buttons on thicker fabrics, increase the thread shank = the distance between the button and the fabric. Buttons sewn on thin fabrics or buttons for decorative purposes only are stitched without a «thread shank».

NOTICE! The adjustment of the thread shank is only possible when using the Button Sew-On Foot #18.

- > Loosen the screw on the back of the presser foot.
- > Push the bar upwards according to the thickness of the fabric.
- > Tighten the screw.

Sewing on a Button

Prerequisite:

- The shank length is adjusted according the fabric thickness.
- The Button Sew-On Foot #18 or an alternative presser foot is fitted.
- The fitted presser foot has been selected in the user interface.
- The feed dog is lowered.



- > Tap «Buttonholes».
- > Select Button Sew-on Program No. 60.
- > Turn the handwheel until the bobbin thread comes up.

- > **NOTICE! The Button sew-on program always starts above the left hole of the button.**
Position the button on the fabric. Place the button and the fabric beneath the needle so that the needle stitches into the left hole.
For buttons with 4 holes, sew the first front pair of holes first.
- > Lower the presser foot.
- > Perform the first stitches in the left hole via the handwheel.
- > Keep turning the handwheel until the needle changes to the right hole. In doing so, check whether the needle goes into the right hole. If necessary, adjust the stitch width by turning the upper Multifunction knob.
- > Hold the threads and push the foot control.
 - The machine sews on the button and stops automatically.
- > For increased stability, sew the Button sew-on Program again.
- > Cut the threads with the machine. Alternatively, pull the sewing projects from under the sewing machine and trim the threads by hand. Pull the upper thread to the wrong side of the fabric and knot it with the bobbin thread.

9.17 Sewing Eyelets



For increased stability sew the eyelet twice. Adjust stitch with the balance if necessary.

Prerequisite:

- The Reverse Pattern Foot #1C or the Open Embroidery Foot #20C is fitted.



- > Tap «Buttonholes».
- > Select Eyelet with Small Zigzag No. 61 or Eyelet with Straight Stitch No. 62.
- > Turn the, «Upper Multi-function Knob» or «Lower Multi-function Knob» to alter the size of the eyelet.
- > Sew the Eyelet Program.
 - The machine stops automatically at the end of the Eyelet Program.
- > Use an awl, punch pliers or a hole punch to open the eyelet.







10 Quilting

10.1 Overview Quilt Stitches



Stitch Pattern	Stitch Number	Name	Description
	No. 1324	Quilting, securing program	To secure at the sewing start and sewing end with short forward stitches.
	No. 1325	Quilting, straight stitch	For machine quilting using a straight stitch with a 3 mm stitch length.
	No. 1326	Patchwork stitch/ straight stitch	For sewing patchwork parts together using a straight stitch with a 2 mm stitch length.
	No. 1327	Stippling Stitch/ Stippling Quilt Stitch	For imitations of stippling stitch.
	No. 1328	Hand-look quilt stitch	For attaching an imitation of hand-look stitch with monofilament.
	No. 1329	Blanket stitch	For applications and sewing on ribbons.
	No. 1330	Double blanket stitch	For applications and sewing on ribbons.
	No. 1331	Narrow blind stitch	For hidden sewing of applications
	No. 1332	Feather Stitch	For quilting, crazy patchwork, embellishing and finishing.
	No. 1333 – No. 1338	Feather Stitch	For quilting, crazy patchwork, embellishing and finishing.
	No. 1339 – No. 1345, No. 1351, No. 1355 – No. 1359, No. 1395 – No. 1398	Decorative Quilt Stitch	For quilting, crazy patchwork, embellishing and finishing.

Stitch Pattern	Stitch Number	Name	Description
	No. 1347, No. 1348, No. 1350	Quilt stitch/hand-look stitch	For attaching an imitation of hand-look stitch with monofilament.
	No. 1352	Dual blanket stitch	For sewing on the edge between two applications – crazy patchwork.
	No. 1353	Dual double blanket stitch	For sewing on the edge between two applications – crazy patchwork.
	No. 1354	Satin stitch	For appliqué.

10.2 Quilting, Securing Program

Prerequisite:

- The Reverse Pattern Foot #1C is fitted.



- > Tap «Quilt Stitches».
- > Select Decorative Quilt Stitch No. 1324.
- > Press the foot control.
 - The machine sews 6 stitches forwards automatically when sewing is started.



- > Sew the required length of seam.
- > Push the button «Quick Reverse».
 - The machine sews 6 stitches forwards automatically and stops automatically at the end of the Securing Program.

10.3 Sewing handlook quilt stitches

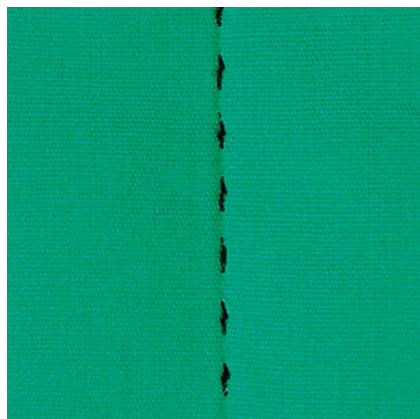

Hand-look quilt stitches are suitable for all fabrics and sewing projects that should look like hand-sewn. It is recommended to use a monofilament thread as upper thread and an embroidery thread as bobbin thread. The sewing speed should be moderate to prevent the monofilament from breaking. If required, the upper thread tension and the balance can be adjusted to the sewing project and the desired quilt stitch.

Prerequisite:

- The Reverse Pattern Foot #1C is fitted.



- > Tap «Quilt Stitches».
- > Select Hand-look quilt stitch No. 1328, No. 1347, No. 1348 or No. 1350.
- > If necessary, adjust the upper thread tension and the balance to suit the sewing project and the desired quilt stitch.
- > To start the machine, press the foot control or push the button «Start/Stop».



10.4 Guiding the Quilt Work Freely



Freehand quilting and darning use the same principle of free movement. With stipple quilting, entire surfaces of the fabric are filled with quilt stitches. The single lines of stitching are rounded and never cross one another.



- Quilting gloves with rubber nubs make it easier to guide the fabric.
- For the best possible results use the High Thread Tension Bobbin Case (optional accessory).
- It is recommended to use the slide-on table and the Free Hand System.
- With free motion quilting, it is of advantage to quilt from the center outwards and to guide the fabric using smooth, round movements to form the design of your choice.

Prerequisite:

- The top layer, the batting and the backing are pinned together or basted.
- The feed dog is lowered.
- The Darning Foot #9 is fitted.



- > Tap «Practical Stitches».
- > Select Straight Stitch No. 1.
- > If required, adjust the upper thread tension.
- > To prevent the fabric from shifting, select the needle position down.
- > To start the machine, press the foot control or push the button «Start/Stop».
- > Hold both hands close to the presser foot like an embroidery hoop to guide the fabric. Make sure that the needle does not pierce the same place several times in a row.
- > To ensure a minimum stitch distance when quilting corners, reduce the embroidery speed.
- > If the thread is lying on top of the fabric, slow down the movement.
- > If there are knots on the wrong side of the fabric, move the fabric more quickly.

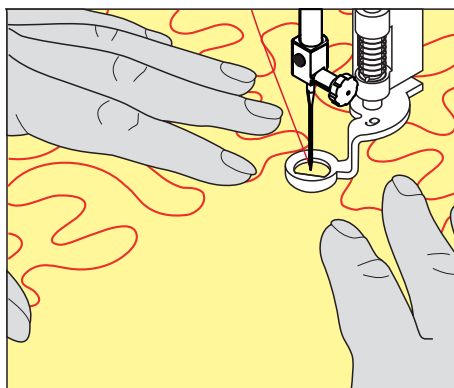

11 BERNINA Stitch Regulator (BSR)

The BERNINA Stitch regulator equalizes the stitch length which results of the free movement of the fabric while free-motion sewing - a sewing technique which grows more and more popular. When free-motion sewing with the BSR presser foot, every stitch is equally long and the stitch formation is perfectly regular.

As soon as the BSR presser foot is attached and the feed dog is lowered, the selection menu of the desired mode appears in the display of the machine. The BSR presser foot can be used with sewing straight stitch as well as zig zag.

The BSR presser foot reacts on the movement of the fabric and therefore controls the speed of the machine up to the highest possible speed. It can be said: The faster the movement of the material, the higher the speed of the machine.

If the fabric is moved too quickly, an acoustic signal sounds. The beeper can be activated or deactivated in the «BSR» display. The sound of the beeper can also be activated or deactivated in the Setup Program.

11.1 BSR Mode 1

The BSR function can be controlled via the foot control or the button «Start/Stop». Start the BSR mode. At the BSR presser foot a red light is on. By moving the fabric the machine accelerates. If the fabric isn't moved, securing in place is possible without pressing an additional button. When working via the foot control or when using the button «Start/Stop», the BSR mode doesn't stop automatically.

11.2 BSR Mode 2

The BSR function can be controlled via the foot control or the button «Start/Stop». The machine starts only when the foot control or the button «Start/Stop» is pressed and the fabric is moved simultaneously. Without moving the fabric, the BSR2 mode stops after 7 seconds. The red light goes off (only when working with the button «Start/Stop»). When working via the foot control, the red light doesn't go off.

11.3 BSR Function with Straight Stitch No. 1

This function allows free-motion quilting with straight stitch and a pre-programmed stitch length up to 4 mm. The programmed stitch length is maintained within a certain speed, independent of the fabric movement.

11.4 BSR Function with Zigzag No. 2

The zig zag can be used e.g. for thread painting. The set stitch length will **not** be maintained when sewing the zig zag stitch, but the BSR function simplifies the application. Anwendung.

11.5 Sewing Preparations for Quilting

Attach the BSR presser foot

Prerequisite:

- The machine is switched off.

NOTICE

The Lens of the BSR Presser Foot is Dirty

The machine doesn't recognize the BSR presser foot.

> Clean the lens with a soft, slightly damp cloth.

> Change the presser foot.

- > Insert the cable of the BSR Foot into the connection (1).



- > Switch the machine on.
 - The BSR display opens and the BSR1 Mode is activated.

Changing the Presser Foot

NOTICE

The Lens of the BSR Presser Foot is Dirty

The machine doesn't recognize the BSR presser foot.

- > Clean the lens with a soft, slightly damp cloth.
-
- > Raise the needle.
 - > Raise the BSR foot.
 - > Switch off the machine.
 - > Remove the BSR foot from the machine.
 - > Press both push buttons at the BSR foot against each other.

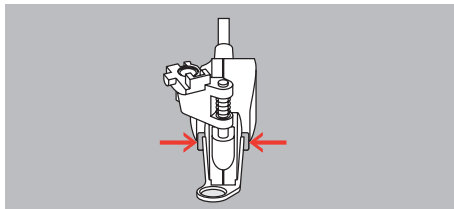

- > Pull the presser foot sole out of the guide downwards.
- > Insert the new presser foot sole into the guide and push upwards until it clicks into place.
- > Attach the BSR presser foot.

11.6 Using the BSR Mode

The BSR function can either be operated via the foot control or via the button «Start/Stop».

Start via the Foot Control: The foot control must be pressed down while quilting is in progress. The machine keeps running in BSR Mode 1 until the foot control is released, even if the fabric is not moved.

If quilting in BSR Mode 2 is stopped, the machine sews another stitch depending on the needle position and stops with needle position up.

Prerequisite:

- The slide-on table has been fitted.
- The knee lifter is attached.



> Lower the feed dog.

> Select the desired BSR Mode.



> To lower the presser foot, push the button «Start/Stop» or press the foot control.

- > To start the BSR Mode, push the button «Start/Stop» again or press and hold the foot control again.
 - A red light is lit on the BSR Presser Foot.



- > Move the fabric to control the speed of the machine in the BSR Mode.
-  > To stop the BSR Mode, push the button «Start/Stop» again or release the foot control.
 - The BSR Mode stops and the red light at the presser foot goes off.
-  > To deactivate the BSR Mode and to quilt without automatic stitch lengths, tap «BSR Mode».



11.7 Securing Stitches

Securing in BSR1 Mode with the Button «Start/Stop»

Prerequisite:

- The BSR presser foot is fitted and connected to the machine.
- The BSR display opens and a BSR1 Mode is active.
- > Lower the feed dog.
- > Lower the presser foot.
-  > Push the button «Needle position Up/Down» 2x.
 - The bobbin thread is brought up.
- > Hold the upper and the bobbin thread.
-  > Push the button «Start/Stop».
 - Start the BSR Mode.
- > Sew 5 – 6 securing stitches.
-  > Push the button «Start/Stop».
 - The BSR Mode stops.
- > Cut the thread.

Securing in BSR2 Mode

Prerequisite:

- The BSR presser foot is fitted and connected to the machine.
- The BSR display opens and a BSR2 Mode is active.
- > Lower the presser foot.
-  > Push the button «Securing Stitches».
- > Press the foot control or push the button «Start/Stop».

By moving the fabric some short securing stitches are sewn, then the programmed stitch length is activated and the securing function is deactivated automatically.

12 My BERNINA Embroidery







12.1 Overview Embroidery module



- | | | | |
|---|--------------------------------|---|-----------------------------|
| 1 | Embroidery arm | 3 | Guide rails for the machine |
| 2 | Coupling for securing the hoop | 4 | Connection to the machine |

12.2 Supplied Accessories Embroidery Module

Overview Accessory Embroidery Module

Illustration	Name	Purpose
	Drop-shaped Embroidery Foot #26	For embroidering, darning and freehand quilting.
	Large Oval Embroidery Hoop	To embroider large embroidery designs or design combinations up to 145 x 255 mm (5.70 x 10.04 in). Template for precise fabric positioning included.
	Medium Embroidery Hoop	To embroider medium-sized embroidery designs up to 100 x 130 mm (3.94 x 5.12 in). Template for precise fabric positioning included.
	Small Embroidery Hoop	To embroider small embroidery motifs up to 72 x 50 mm (2.83 x 1.97 in). For free arm embroidering with closed sewing projects such as sleeves, trouser legs or socks. Including the template for precise fabric positioning.
	Embroidery Needle Assortment	For embroidering.
	Template Holder	To place and remove the template in or out of the embroidery hoop.
	Spool Net	For even thread unwinding with smooth threads from the thread spool, e.g. nylon, rayon, silk threads or metallic yarns.

12.3 Overview User Interface

Overview functions/visual information



- | | | | |
|---|---|---|--------------------------|
| 1 | «Upper Thread Tension» | 5 | «Stitch Plate Selection» |
| 2 | «Needle Selection» | 6 | «Feed Dog Indicator» |
| 3 | «Presser Foot Indicator/Presser Foot Selection» | 7 | «Bobbin Thread» |
| 4 | «Hoop Indicator/Select Hoop» | | |

Overview System settings



- | | | | |
|---|-------------------------|---|------------------|
| 1 | «Home» | 5 | «Help» |
| 2 | «Setup Program» | 6 | «eco Mode» |
| 3 | «Tutorial» | 7 | «Clear Settings» |
| 4 | «Embroidery Consultant» | | |

Overview Selection Menu Embroidery



- | | | | |
|---|-------------|---|---------------------|
| 1 | «Selection» | 3 | «Color Information» |
| 2 | «Edit» | 4 | «Embroidery» |

13 Embroidery preparation

13.1 Attaching the Module

NOTICE

Transporting the Embroidery Module

Damage to the embroidery module connection and machine.

- > Remove the embroidery module before transporting the machine.

Prerequisite:

- Extension table must not be fitted.
- > Make sure that the module and the machine are placed on a stable, even surface.
- > Ensure that the embroidery arm can move freely.
- > Lift the embroidery module on the left side.
- > Carefully push the module from left to right into the embroidery module connection (1) of the machine.

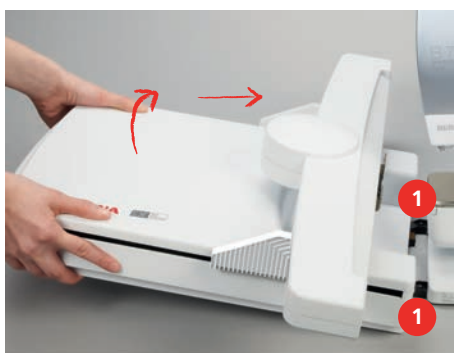

- > To remove, lift the embroidery module on the left and carefully pull to the left.



13.2 Preparing the Machine

Lowering the feed dog

- > Push the button «Feed Dog Up/Down».



Selecting the embroidery motif

All of the embroidery designs can be either directly embroidered or can be changed using different functions offered by the embroidering machine. You can find all embroidery designs at the end of the instruction manual. All the stitch patterns contained in the sewing mode can also be embroidered. The stitch patterns are displayed in files, sorted in Categories, like in the sewing mode. In addition to that, embroidery designs can be downloaded from the Personal Memory or from the USB stick (optional accessory).



> Tap «Home».



> Tap «Embroidery Mode».

> Select an alphabet, embroidery design, stitch pattern or a personal embroidery design from a file.

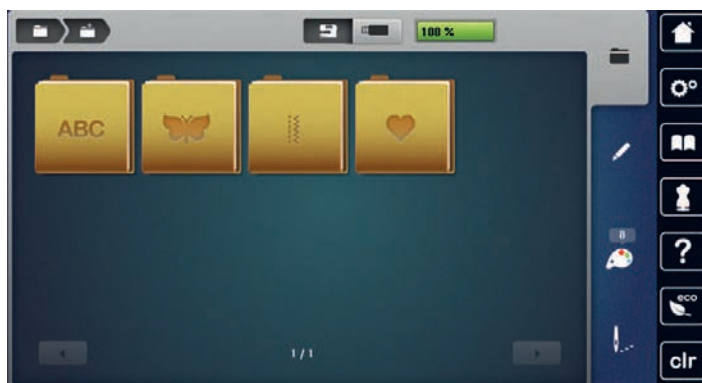

13.3 Embroidery Foot

Attaching the embroidery foot

- > Raise the needle.
- > Raise the presser foot.
- > Switch off the machine.
- > Push the clamping lever up.
- > Remove the presser foot.
- > Insert the embroidery foot from below into the bracket.
- > Press the clamping lever down.



Selecting the Stitch Plate in the User Interface

After fitting the corresponding embroidery foot, it can be selected and saved on the machine. Furthermore, any alternative feet that are available for the respectively selected embroidery design are displayed.

- > Switch the machine on.
- > Select the embroidery design.

- > Tap «Presser Foot Indicator/Presser Foot Selection».



- > To display all suitable presser feet for the selected embroidery design, tap «Optional Presser Feet».
- > Select the fitted embroidery foot.

13.4 Needle and Stitch Plate

Inserting the embroidery needle



Embroidery needles of the type 130/705 H-SUK provide a larger eye and are slightly rounded. This avoids thread abrasion when using Rayon- and cotton embroidery thread. Depending on the embroidery thread use a size No. 70-SUK to No. 90-SUK needle.

- > Raise the needle.
- > Switch off the machine.
- > Remove the fitted foot.
- > Loosen the fixing screw of the needle using the screwdriver gray Torx.



- > Pull the needle down.
- > Hold the new needle with the flat side to the back.
- > Insert the needle as far as it will go.
- > Tighten the needle clamp using the gray Torx screwdriver.

Selecting the embroidery needle in the User Interface

After changing the needle, you can check whether this can be used with the selected stitch plate.



- > Tap «Needle Selection».

- > Select the fitted needle.



- If the selected needle is suitable in combination with the stitch plate, embroidering can be started.
- If the selected needle is not suitable in combination with the stitch plate, starting the machine is automatically blocked.

Selecting needle type and needle size

Convenient memory function: To prevent a loss of information, the needle type and the needle size can be saved additionally on the machine. The saved needle type and the saved needle size can be checked at any time.



- > Tap «Needle Selection».



- > Tap «Needle Information».



- > Select the needle type (1) of the fitted needle.
- > Select the needle type (2) of the fitted needle.

Attaching the stitch plate

The stitch plate (Straight and CutWork Stitch Plate) has a small hole in the needle area. The stitch formation (thread knotting of upper and bobbin thread) is thus optimized. This results in a more beautiful stitch appearance.

- > To lower the feed dog, push the button «Feed Dog Up/Down».



- > Switch off the machine.
- > Remove the needle.

- > Remove the presser foot.
- > At the marking on the upper right corner of the stitch plate, push the stitch plate downwards until it tips.



- > Remove the stitch plate.
- > Place the opening of the stitch plate (Straight and CutWork Stitch Plate) above the corresponding guide pins and press it down until it clicks into place.

Selecting the stitch plate in the User Interface

After changing the stitch plate, you can check whether it can be used with the selected needle.



- > Tap «Stitch Plate Selection».
- > Select Straight and CutWork Stitch Plate.

Thread-up Command

The machine must be ready for embroidery to bring up the bobbin thread. The bobbin thread can be brought up in one step for a manual knotting. If no securing stitches are wanted, it is recommended to deactivate the securing stitches in the Setup.



- > Hold the upper thread.
- > Push the button «Presser Foot Up/Down».
 - The bobbin thread is brought up automatically.

13.5 Embroidery Hoops

Overview Embroidery Hoop Selection

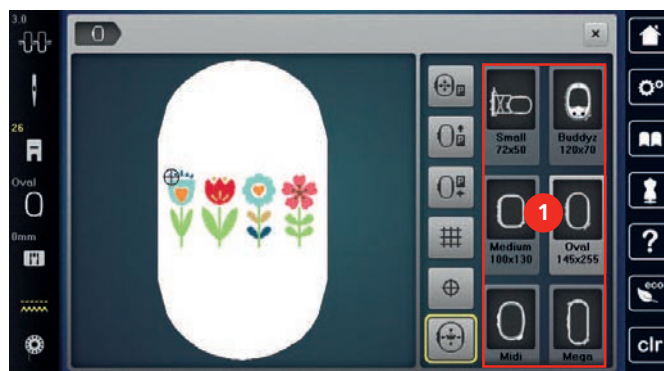

1 Hoop Selection

Selecting the Embroidery Hoop

The best embroidery result is achieved when the smallest possible embroidery hoop for the embroidery design is selected.

The embroidery design has a pre-set size which is displayed.

Prerequisite:

- The embroidery design is selected.



- > Tap «Hoop Indicator/Select Hoop».
 - The machine selects the optimal embroidery hoop according to the size of the embroidery design automatically. If the preset embroidery hoop is not available, another desired embroidery hoop can be selected. When an embroidery hoop is attached which does not correspond with the selected one, the attached hoop is considered active and the embroidery design area is displayed accordingly.
- > Select the desired embroidery hoop.

Tear-away Stabilizers

Using a stabilizer ensure more stability of the embroidery project. A tear-away stabilizer suits all woven and non-stretch materials. 1 – 2 layers can be used. Stabilizers are available in different weights. With larger areas to be embroidered the stabilizer will remain under the embroidery thread. The stabilizer is applied to the wrong side of the fabric with temporary adhesive spray. Carefully cut away excess stabilizer after embroidering.

Cut-away Stabilizers

Using a stabilizer ensure more stability of the embroidery project. A cut-away stabilizer suits all elastic materials. 1 – 2 layers can be used. Stabilizers are available in different weights. With larger areas to be embroidered the stabilizer will remain under the embroidery thread. The stabilizer is applied to the wrong side of the fabric with temporary adhesive spray. Carefully cut away excess stabilizer after embroidering.

Using Adhesive Spray

The application of spray adhesive is recommended for stretch and smooth materials and knitware. It prevents the fabric from losing shape and slipping. Appliqués can be exactly positioned with spray adhesive. The spray adhesive shouldn't be used near the machine to avoid contamination.

- > Use the spray adhesive carefully at a distance 25 – 30 cm (9 – 12 inch) when spraying the stabilizer.
- > Adhere the sprayed stabilizer to the wrong side of the fabric carefully, smoothing material so there are no puckers.
- > Position smaller parts such as pocket flaps or collars on the stabilizer.
- > To avoid the possibility of getting hoop marks when working with napped materials or fleece, don't hoop the parts but spray the stabilizer and hoop it.
- > Adhere the fabric to be embroidered.
- > Remove any adhesive residue before starting the machine.

Using Spray Starch

Spray starch is ideal for additional stiffening fine, loosely woven materials. Always use an additional stabilizer on the wrong side of the material.

- > Spray the area to be embroidered.
- > Let it dry or press gently with a warm iron if necessary.

Using Iron-on Interfacing

Iron-on interfacings are available in a variety of weights. It is recommended to use an iron-on interfacing which is easily removable from the basic fabric. An Iron-on interfacing suits all materials that are easily distorted like stretch fabric such as tricot and jersey.

- > Iron-on interfacings are ironed to the wrong side of the material using a warm iron.

Using Paper-backed Adhesive Stabilizer

Paper-backed adhesive stabilizers are intended to be used for fabrics such as jersey and silk as well as for embroidery projects which are not suited to be hooped in the embroidery hoop.

- > Place the stabilizer in the hoop, so that the paper side is up.
- > Use a pair of scissors to score the paper and remove paper in the hoop area.
- > Position the fabric to be embroidered on the stabilizer and press it on place.
- > Remove any adhesive residue before starting the machine.

Using Water-soluble Stabilizer



For lace embroidery it is recommended to hoop 1 - 3 layers of water-soluble stabilizer in the embroidery hoop. As the embroidery design is not embroidered on the fabric, only the thread embroidered design is left. The embroidery designs should be combined with short stitches otherwise the individual designs may fall out.

Water-soluble stabilizers are ideal for fine, sheer fabrics where other stabilizers may show through the embroidery stitches as well as for lace embroidery. The stabilizer dissolves in water. Water-soluble stabilizers are an ideal protection for looped pile fabrics preventing the loops from being damaged. It prevents threads from sinking into the material and keeps the fabric pile from poking through the embroidery.

- > Place the stabilizer on the underside of the material.
- > Use adhesive spray to adhere stabilizer if necessary.
- > For material with a pile, reinforce with additional, suitable stabilizer on the wrong side.
- > Place all the layers together into the embroidery hoop.
- > After dissolving, lay the motif down flat and let dry.

Preparing the Embroidery Hoop

The embroidery hoop consists of an outer and an inner hoop. There is a corresponding template for every hoop. The area to be embroidered is marked in 1 cm (0.39 inch) squares. The center and corner points are marked with holes. The required marks can be transferred to the material.

- > Mark the center of an embroidery design on the fabric, using a water-soluble pen.

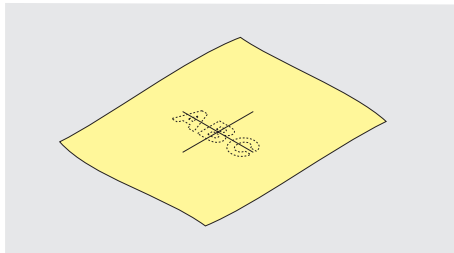

- > Loosen the screw on the outer hoop.
- > Remove the inner hoop.
- > Make sure that the arrows marks of both hoops match.
- > Attach the template holder.
- > Place the template in the inner hoop, so the BERNINA logo is at the front edge at the arrow mark until it clicks into place.

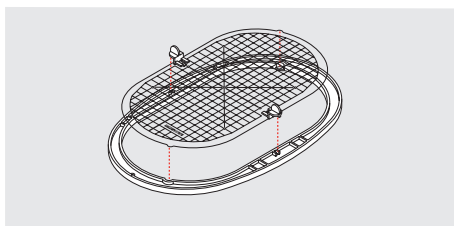

- > Place the fabric under the inner hoop.
- > Line up the marked center point on the center of the template.
- > Place the material and the inner hoop on the outer hoop, so that the arrow markings of both hoops are aligned.

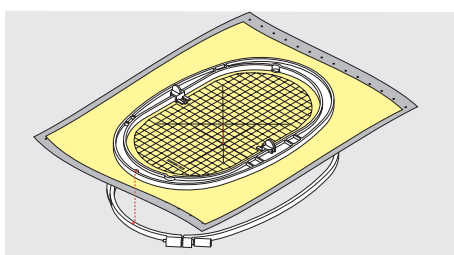

- > Fit the hoops into each other so that the material does not move.
- > Hoop the fabric tautly in the embroidery hoop.
- > Tighten the screw.
- > Remove the template from the hoop by using the template holder.
- > To avoid scratches on the free arm, press the inner hoop into the outer hoop so that the inner hoop including the fabric protrudes downwards by up to 1 mm.

Attaching the Hoop

- > Raise the needle.
- > Raise the embroidery foot.
- > Hold the hoop with the right side of the fabric up with the attaching mechanism to the left.
- > Position the hoop below the embroidery foot.
- > Press both attaching mechanisms (1) of the hoop towards each other.
- > Position the embroidery hoop (2) above the bracket of the embroidery arm.
- > Press the hoop down until it clicks in position.
- > Release the attaching mechanism (1).

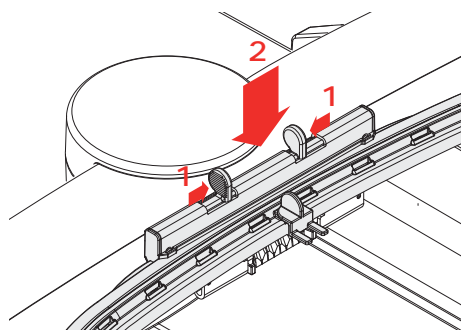

- > Press the attaching mechanisms of the hoop towards each other to remove the hoop.
- > Remove the hoop.

Overview Embroidery functions

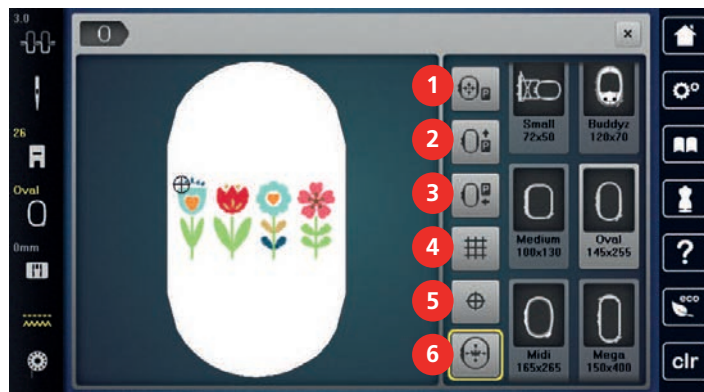

- | | |
|---|---------------------------------|
| 1 «Centering the Needle to the Embroidery Hoop» | 4 «Grid On/Off» |
| 2 «Move Hoop to the Back» | 5 «Center of Embroidery Design» |
| 3 «Move Hoop to the Left» | 6 «Virtual Positioning» |

Centering the Needle to the Embroidery Hoop

Relocating the embroidery hoop facilitates threading when the needle is close to the embroidery hoop.



- > Tap «Hoop Indicator/Select Hoop».



- > Tap «Centering the Needle to the Embroidery Hoop».
- > Thread the upper thread.



- > To move the hoop back to its previous position, push the button «Start/Stop».

Move Hoop to the Back

To facilitate changing the bobbin, it is recommended to move the hoop to the back before threading. This makes it easier to open the bobbin cover.



- > Tap «Hoop Indicator/Select Hoop».



- > Tap «Move Hoop to the Back».
- > Thread the bobbin thread. (see page 46)



- > To move the hoop back to its previous position, push the button «Start/Stop». If necessary, pull back the upper thread.

Moving the Module for the Sewing Mode

The embroidery module can be positioned so that any sewing projects can be carried out even if the module is connected.



- > Tap «Hoop Indicator/Select Hoop».
- > Remove the hoop.



- > Tap «Move Hoop to the Left».



- > Tap «Home».



- > Tap «Sewing Mode».

Grid On/Off

When the center of the hoop and the grid are displayed, the embroidery design can be positioned more exactly.



- > Tap «Hoop Indicator/Select Hoop».



- > To show the hoop center on the display, tap «Grid On/Off».
- > To show the grid lines, tap «Grid On/Off» again.
- > To hide the hoop center and the grid lines, tap «Grid On/Off» again.

Locating the Center of the Embroidery Design

The embroidery hoop is positioned so that the needle is exactly above the center of the embroidery design or the motif begin.



- > Tap «Hoop Indicator/Select Hoop».



- > To position the hoop so that the needle is placed exactly over the center of the embroidery design, tap «Center of Embroidery Design».
- > To position the hoop so that the needle is placed exactly over the motif start, tap «Center of Embroidery Design» again.

Virtual Positioning of the Embroidery Hoop

The embroidery hoop is automatically moved to the new position as soon as the embroidery design is repositioned. Therefore, the icon «Virtual Positioning» is activated automatically and outlined in yellow when an embroidery hoop is attached.

Prerequisite:

- The hoop is attached.



> Tap «Hoop Indicator/Select Hoop».



> To deactivate the automatic movement of the hoop after repositioning the embroidery design, tap «Virtual Positioning».

– The «Virtual Positioning» is not yellow-outlined.

> To activate the automatic movement of the hoop after repositioning the embroidery design, tap «Virtual Positioning» again.



15 Creative Embroidering

15.1 Overview Embroidering

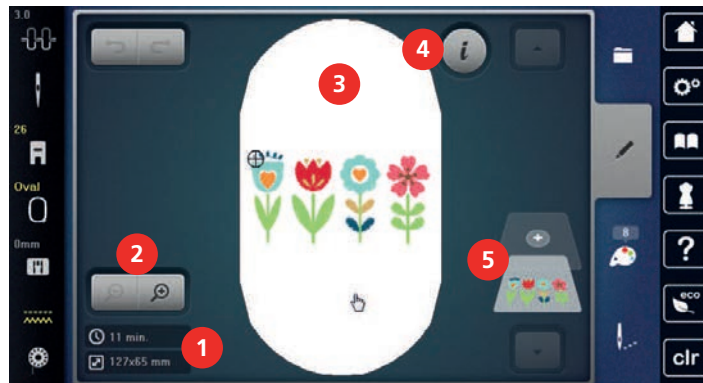

- | | | | |
|---|--|---|--------------------------|
| 1 | Embroidery Time/Embroidery Design Size | 4 | «i-Dialog» |
| 2 | Scaling Up, Downsizing and Moving the Embroidery Design View | 5 | Embroidery design Layers |
| 3 | Area to be Embroidered | | |

15.2 Selecting and Changing the Embroidery Design



> Tap «Selection».



- > Tap «Loading the Embroidery Design».
- > Select a new embroidery design.

15.3 Checking the Embroidery Time and the Embroidery Design Size

In the selection menu «Edit» the estimated embroidery time in minutes as well as the width and height of the embroidery design is indicated at lower left (1).



15.4 Regulating the Speed

The sewing speed can be adjusted infinitely variable with the slide.

- > Move the slide to the left to reduce the sewing speed.
- > Move the slide to the right to increase the sewing speed.

15.5 Editing the Embroidery Design



Overview Editing embroidery motif



- | | | | |
|---|----------------------------------|----|---|
| 1 | «Move View» | 10 | «Mirror Image Up/Down» |
| 2 | «Moving the Embroidery Design» | 11 | «Duplicating» |
| 3 | «Zoom Out» | 12 | «Endless Embroidery» |
| 4 | «Zoom In» | 13 | «Deleting an Embroidery Design» |
| 5 | «Moving the Embroidery Design» | 14 | «Check Embroidery Design Size» |
| 6 | «Rotating the Embroidery Design» | 15 | «WordArt»
(activated after text entry) |
| 7 | «Change Design Size» | 16 | «Group Embroidery Designs» |
| 8 | «Pinpoint Placement» | 17 | «Change Embroidery Design Sequence»
(becomes visible by scrolling) |
| 9 | «Mirror Image Left/Right» | 18 | «Alter Stitch Type/Stitch Density»
(becomes visible by scrolling) |

Scaling Up the Embroidery Design View

The view of the embroidery design can be scaled up. In addition to that, the view can be adjusted with or without changing the embroidery position.

- > Select the embroidery design.
-  > To edit the view of the embroidery design, tap «Zoom In».
-  > To scale up the view of the embroidery design, tap «Zoom In» 1 up to 4 times.
-  > To get back to the Edit Mode, tap «Zoom Out» 1 up to 4 times.

Downsizing the Embroidery Design

The view of the embroidery design can be downsized. In addition to that, the view can be adjusted with or without changing the embroidery position.

- > Select the embroidery design.
-  > To edit the view of the embroidery design, tap «Zoom In».
-  > To downsize the view of the enlarged embroidery design gradually, tap «Zoom Out» 1 – 4 times.

Moving the Embroidery Design View



The view of the embroidery design can be moved. In addition to that, the view can be adjusted with or without changing the embroidery position.

- > Select the embroidery design.
-  > To activate «Move View», tap «Zoom In».
 - «Move View» is activated (dark gray).

- > Move the view of the embroidery design.
 - The embroidery position is not altered.
-  > To get back to the Edit Mode, tap «Zoom Out».

Moving the Embroidery Design in Enlarged View

In addition to that, the view can be adjusted with or without changing the embroidery position. In addition to that, the view can be adjusted with or without changing the embroidery position.

- > Select the embroidery design.
-  > To display the icon «Relocating a Stitch Pattern», tap «Zoom In».
-  > Tap «Moving the Embroidery Design».
 - The icon turns dark gray.
- > Move the view of the embroidery design.
 - The embroidery position is altered.
-  > To get back to the Edit Mode, tap «Zoom Out».

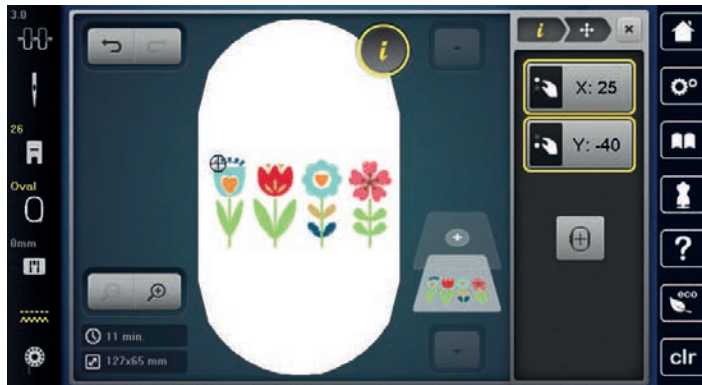

Moving the Embroidery Design

- > Select an embroidery motif.
-  > Tap «i-Dialog».
-  > Tap «Moving the Embroidery Design».
 - > Turn the «Upper Multi-function knob» to move the embroidery motif horizontally in 1/10-mm steps.
 - > Turn the «Lower Multi-function knob» to move the embroidery motif vertically in 1/10 mm steps or tap and hold the embroidery motif to move the embroidery motif as you like.
 - The relocation is indicated in the yellow-outlined icons.



-  > Tap «Centering the Embroidery Design».
 - The embroidery motif is repositioned in the center of the embroidery hoop.

Rotating the Embroidery Design

- > Select the embroidery design.
-  > Tap «i-Dialog».
-  > Tap «Rotating the Embroidery Design».
 - > Turn the «Upper Multi-function Knob» or the «Lower Multi-function Knob» to the right to rotate the embroidery design clockwise.
 - > Turn the «Upper Multi-function Knob» or the «Lower Multi-function Knob» to the left to rotate the embroidery design counter-clockwise.
-  > To rotate the embroidery design in 90°-steps, tap «Rotate the Embroidery Design +90°».

Altering the Embroidery Design Size Proportionally



Enlargements or reductions of the motif size up to maximum 20 % achieve the best results.

If the motif size is to be altered by more than 20 %, the motif should be adapted in a separate embroidery software and then reloaded onto the machine.



- > Select the embroidery design.
- > Tap «i-Dialog».



- > Tap «Change Design Size».



- > If «Retain Proportions» is not outlined in white, tap «Retain Proportions».
 - «Retain Proportions» is outlined in white.



- > Turn the «Upper/Lower Multi-function Knob» to the right to scale up the embroidery design proportionally.
- > Turn the «Upper/Lower Multi-function Knob» to the left to downsize the embroidery design proportionally.

Altering the Embroidery Design Size Disproportionally



Enlargements or reductions of the motif size up to maximum 20 % achieve the best results.

If the motif size is to be altered by more than 20 %, the motif should be adapted in a separate embroidery software and then reloaded onto the machine.



- > Select the embroidery design.
- > Tap «i-Dialog».



- > Tap «Change Design Size».



- > If «Retain Proportions» is outlined in white, tap «Retain Proportions».
 - «Retain Proportions» is not outlined in white.



- > To make the embroidery design wider, turn the «Upper Multi-function Knob» clockwise.
- > To make the embroidery design narrower, turn the «Upper Multi-function Knob» anti-clockwise.
- > To make the embroidery design longer, turn the «Lower Multi-function Knob» clockwise.
- > To make the embroidery design shorter, turn the «Lower Multi-function Knob» anti-clockwise.

Mirroring Embroidery Designs

Embroidery designs can be mirror-imaged both vertically and horizontally.

- > Select the embroidery design.
- > Tap «i-Dialog».



- > To mirror the embroidery design horizontally, tap «Mirror Image Left/Right».



- > To mirror the embroidery design vertically, tap «Mirror Image Up/Down».

Changing the Stitch Type

If the satin stitches are too long, they can be changed to step stitches.

- > Select the Embroidery Design.
- > Tap «i-Dialog».



- > Tap «Alter Stitch Type/Stitch Density».



- > Touch the switch in the upper section of the display (1) to change the satin stitch to the step stitch.
- > Set and confirm the stitch length 2.

Altering the Stitch Density

If the satin stitches are embroidered too densely, the stitch density can be adjusted.

- > Select the embroidery design.
- > Tap «i-Dialog».





- > Tap «Alter Stitch Type/Stitch Density».



- > Adjust the stitch density (1).

Checking the Size and the Position of the Embroidery Design

It can be checked whether or not the embroidery design matches the designated position/location on the fabric. Points which are beyond the embroidery hoop are not traveled to.

- > Select the embroidery design.
- > Tap «i-Dialog».



- > Tap «Check Embroidery Design Size».
 - The embroidery hoop travels all the way until the needle is at the position as it is indicated in the display.

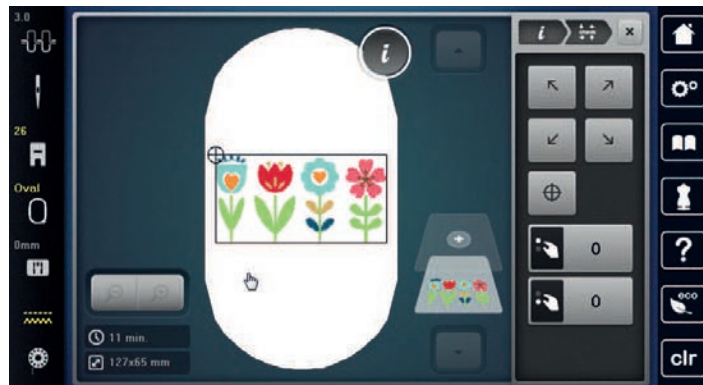

- > To select the desired corner of the embroidery design, tap the respective arrow.
 - The embroidery hoop travels all the way until the needle is at the position as it is indicated in the display. If the embroidery design hasn't been positioned correctly yet, the position can be altered via the «Upper/Lower Multi-function knobs» and the complete embroidery positions can be checked again.



- > To position the needle in the center of the embroidery design, tap «Center of Embroidery Design».
- > Turn the «Upper Multi-function Knob» to move the embroidery design horizontally.
- > Turn the «Lower Multi-function Knob» to move the embroidery design vertically.

Endless Embroidery

When embroidering a trim, it is advantageous to use the Mega Embroidery Hoop (optional accessory) or the Maxi Embroidery Hoop (optional accessory). The embroidering project therefore does not have to be re-clamped as frequently. We recommend marking guide lines on the fabric and using the pattern when clamping and re-clamping in the hoop. In doing so, the guide lines must run parallel to the pattern. The following example, the supplied Oval Hoop is used.

- > Select the embroidery design.
- > Tap «i-Dialog».





- > Tap «Endless Embroidery».
 - The embroidery design is duplicated to the optimum number, suitable for the hoop.
 - The reference points, which are required when re-clamping the fabric, are inserted.
- > If required, use the arrow icons (1) to insert additional reference points.
- > To set the number of embroidery designs, tap «Minus»/«Plus» (2).
- > To specify the distance between the embroidery designs, tap «Minus»/«Plus» (3).



- > To automatically fit all embroidery designs into the hoop, tap «Adapting the Embroidery Design Size to the Hoop» (4).



- > Tap «Confirm».

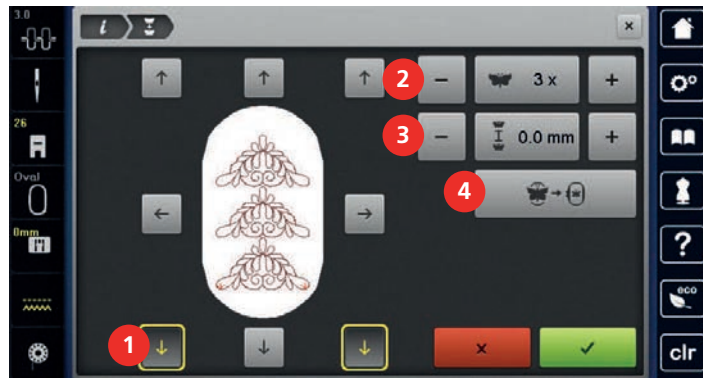

- > Tap «i-Dialog».



- > Tap «Embroidery».



- > Press the button «Start/Stop» and embroider the trim.
 - The embroidery design must be embroidered already.

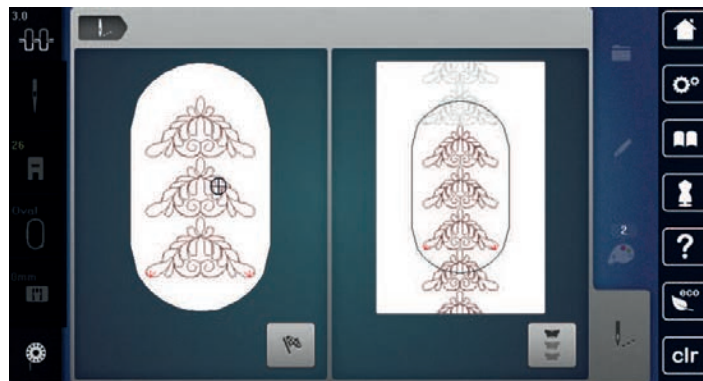

- > After the reference points have been embroidered, tap «Endless Embroidery».
 - An animation displays that the fabric has to be re-clamped.

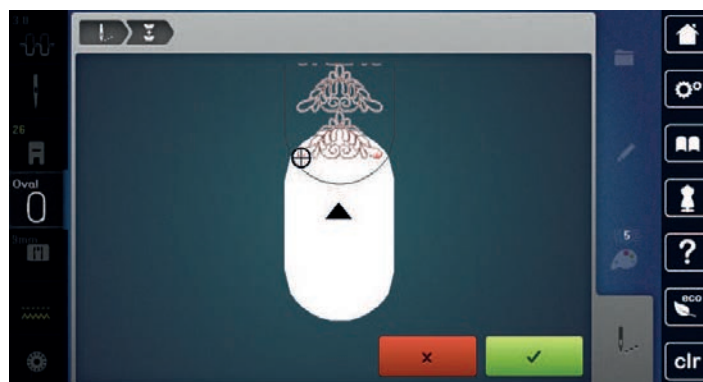

- > Remove the hoop and spin the fabric in such a way that the embroidered reference points are in the upper embroidery field of the hoop and the reference points are located at least 3 cm (1.18 inch) away from the upper edge of the hoop.
- > Attach the hoop.
- ✓ > Tap «Confirm».
 - The hoop is automatically moved close to the reference point.
 - The icon «AUTO» is active and the hoop automatically moves close to the last reference point.
- > Use the arrow icons to determine the side of the embroidered section on which you want to position the next reference point.
- > To position the embroidery hoop precisely, turn the «Upper Multi-function Knob» or «Lower Multi-function Knob».

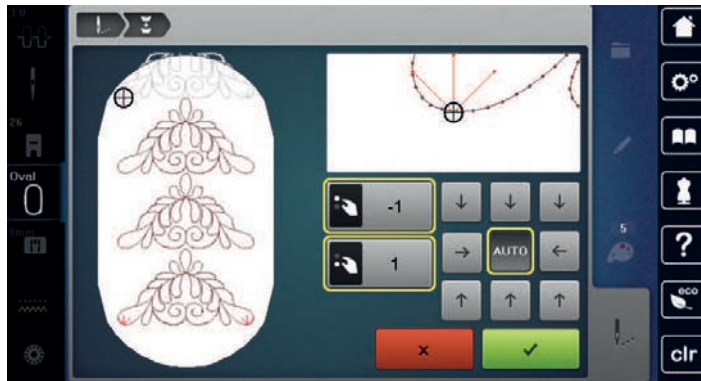

- ✓ > Tap «Confirm».
- ⏻ > Press the button «Start/Stop» and continue embroidering.
- > Repeat these steps until the required length of the trim has been achieved.

Duplicating the Embroidery Design

- > Select the embroidery design.
- > Tap «i-Dialog».



- > Tap «Duplicating».
 - The embroidery design (1) is duplicated (2).



Deleting an Embroidery Design

The active embroidery design is deleted.

- > Select the embroidery design.
- > Tap «i-Dialog».



- > Tap «Deleting».

Changing the sequence within an embroidery motif combination

The sequence of the embroidery motifs in the embroidery motif combination can be changed.

Prerequisite:

- The embroidery motif combination has been created or the motif has been ungrouped.



> Tap «i-Dialog».



> Tap «Change Embroidery Design Sequence».

> Select the required embroidery motif and move it to the corresponding position.

Undoing entries

All entries can be undone step by step and restored as well.

Prerequisite:

- An embroidery design is selected and alterations have been made.



> To undo the last entry, tap «Undo Entries».

> To undo the last entries in sequence, tap «Undo Entries» several times.



> To restore the last entry, tap «Redo Entries».

> To restore the last entries in sequence, tap «Redo Entries» several times.

Grouping embroidery motifs

Embroidery motifs can be added to or removed from a group. The grouped embroidery motifs can be processed in the same way as for one embroidery motif.

The sequence of the embroidery motifs in the group can be changed. (see page 150)

If the grouping of a embroidery motif has been canceled, i.e. the embroidery motif has been broken down into different elements/colors, the colors are no longer combined for new groupings. With alphabets, the length of the connecting stitches must first be set to 1 in the setup. The cancellation of the group then works for all letters.

> Create an embroidery motif combination.

> Select the embroidery motif (1) in the embroidery motif combination.



> Tap «i-Dialog».



> Tap «Group Embroidery Designs».



> Tap «Group».

– Embroidery motifs above the selected embroidery motif are added to the embroidery motif group.

> Select the embroidery motif group.

- > Tap «Ungroup».
 - The grouping is canceled.

or

- > Create an embroidery motif combination.
- > Select all embroidery motifs (2).

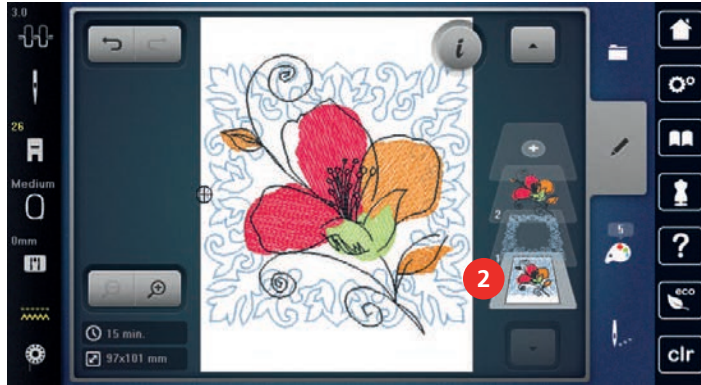

- > Tap «i-Dialog».

- > Tap «Group».
 - All embroidery motifs are added to the embroidery motif group.
- > Select the embroidery motif group.

- > Tap «Ungroup».
 - The grouping is canceled.

15.6 Pinpoint Placement

Positioning of grid points

This function allows the exact positioning of the embroidery design on the fabric in an easy way. The positioning points can be placed in the grid.

Prerequisite:

- Any two points of the embroidery design are marked with chalk or a water-soluble pen on the fabric. The place or the location where the embroidery design is to be positioned is clearly visible.
- The hoop in use is selected.

- > Select the embroidery design.
- > Tap «i-Dialog».



- > Tap «Pinpoint Placement».



- > Tap «Grid Point Positioning».
 - The embroidery design is given a grid with nine different location/positioning points.
- > Select the desired positioning point to which the embroidery design is to be adjusted.
 - The point changes color.
- > Turn the «Upper Multi-function Knob» or the «Lower Multi-function Knob» to the left or to the right to position the needle above the respective mark on the fabric.



- > To confirm the changed position, tap «Set».
 - The point changes color and is set.
- > Select the second positioning point of the embroidery design.

- > Turn the «Upper Multi-function Knob» or the «Lower Multi-function Knob» to the left or to the right to position the needle above the respective mark on the fabric.

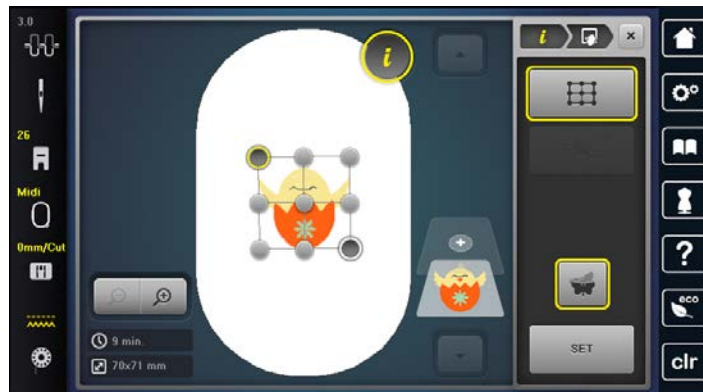

- > To confirm the changed position, tap «Set».
 - The point changes color and is set. The embroidery design is adjusted accordingly.
- > To reset the changes and revert to the default settings, tap «Reset Pinpoint Placement».



Free point positioning

This function allows the exact positioning of the embroidery design on the fabric in an easy way. The points can be defined as you like within the embroidery design.

Prerequisite:

- Any two points of the embroidery design are marked with chalk or a water-soluble pen on the fabric. The place or the location where the embroidery design is to be positioned is clearly visible.
- The hoop in use is selected.

- > Select the embroidery design.
- > Tap «i-Dialog».



- > Tap «Pinpoint Placement».



- > Tap «Free Point Positioning».
- > Define a desired point within the embroidery design.
 - The positioning point is displayed.



- > Turn the «Upper Multi-function Knob» or the «Lower Multi-function Knob» to the left or to the right to position the needle above the respective mark on the fabric.

- > To confirm the changed position, tap «Set».
 - The point changes color and is set.



- > Select the second positioning point of the embroidery design.
- > Turn the «Upper Multi-function Knob» or the «Lower Multi-function Knob» to the left or to the right to position the needle above the respective mark on the fabric.



- > To confirm the changed position, tap «Set».
 - The point changes color and is set. The embroidery design is adjusted accordingly.
- > To reset the changes and revert to the default settings, tap «Reset Pinpoint Placement».



15.7 Combining Embroidery Designs

Combining Embroidery Designs

In the Combi-mode several embroidery designs can be combined.

- > Select the embroidery design.
- > Tap «Adding an Embroidery Design».



- > Select another embroidery design.

Deleting a Single Embroidery Design

Prerequisite:

- A combination of embroidery designs has been created.
- > Tap the desired embroidery design in the area of the embroidery design level (1), keep it touched and drag it outwards.
 - A new window opens.



- > To delete the selected embroidery design, tap «Confirm».

Duplicating the embroidery motif

- > Select an embroidery motif.
- > Tap «i-Dialog».



- > Tap «Duplicating».
- The embroidery motif (1) is duplicated (2).



Duplicating a combination

When a combination is duplicated, the individual embroidery motifs cannot be selected anymore.

- > Select an embroidery motif.
- > Tap «Adding an Embroidery Design».
- > Select another embroidery motif.
- > Select the combination (1).



- > Tap «i-Dialog».

- > Tap «Duplicating».
- The combination is duplicated (2).

15.8 Creating Lettering

Overview embroidery alphabets

Embroidery motif		Name
ABC	ABC	Drifter
ABC	ABC	Childs Play

Embroidery motif		Name
ABC		Victoria
<i>ABC</i>	<i>A B C</i>	Anniversary
ABC	A B C	Swiss Block
ABC		Quilt Block
ABC		Old English
АБВ	А Б В	Russian Textbook
ABC		Happy Times
ABC		Bamboo
<i>ABC</i>		Lisa
<i>ABC</i>		Zurich
ABC		Flare Serif
ABC		Chicago
ABC		Deco block
ABC		Condensed Sans
<i>ABC</i>		Curly
ABC		Rounded Sans

Creating Lettering



- | | | | |
|---|-------------------------|---|---------------------------------------|
| 1 | Entry Field | 5 | «Numbers and Mathematical Characters» |
| 2 | «Deleting» | 6 | «Special Characters» |
| 3 | «Upper Case Characters» | 7 | «Cancel» |
| 4 | «Lower Case Characters» | 8 | «Confirm» |



A lettering is always embroidered in one color. To embroider individual letters or individual words in a different color, the grouping must be canceled.

Lettering can be positioned within the hoop as you like. When the embroidery design is positioned outside the area to be embroidered, the hoop is outlined in red on the display. By means of the hoop selection it is possible to check whether or not the embroidery design can be embroidered in another hoop. If a lettering does not fit into one hoop, individual words can be combined and positioned one below one another, for example.



- > Select «Alphabets».
- > Select an alphabet.
- > Enter and confirm the text.

Editing the Lettering



- > A lettering has been created.
- > Tap «i-Dialog».



- > Tap «WordArt».
- > To change the distance between the characters in increments of one millimeter, turn the «Upper Multi-function Knob».
- > Turn the «Lower Multi-function Knob» to the left or right to curve the writing upwards or downwards.

15.9 Changing the Colors of the Embroidery Design

Overview changing the color



- | | | | |
|---|----------------------------|---|------------------------|
| 1 | «Color Indication» | 4 | «Assign Thread Brand» |
| 2 | Preview for Selected Color | 5 | «Altering Color/Brand» |
| 3 | «Color Wheel» | 6 | «Color Information» |

Changing the colors



A lettering is always embroidered in one color. To embroider individual letters or individual words in a different color, the grouping must be canceled.

- > Select the embroidery design.
- > Tap «Color Information».
- > Tap «Altering Color/Brand» next to the color that needs to be changed.
- > To select the color by entering the color number, tap «Color Selection via Number».
- > Select the desired color.
- > To apply the color choice, tap «Color Information».

Altering the colors via the color wheel

- > Tap «Color Information».
- > Tap «Color Wheel» (1).

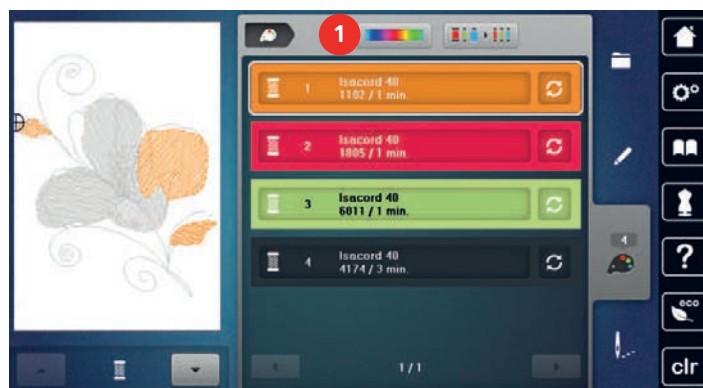

- > To change the colors of the embroidery design, turn the knob (2) clockwise or counterclockwise.

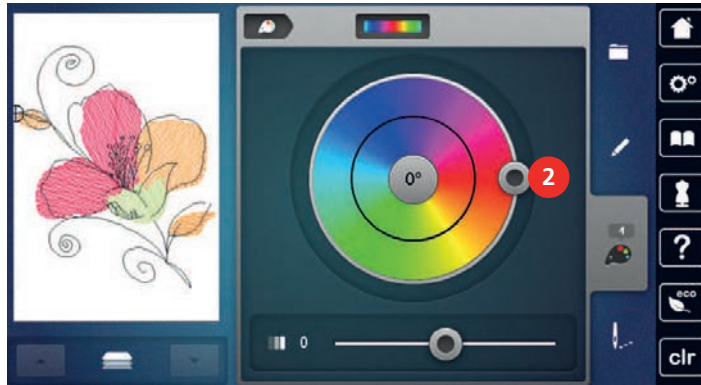

- > To undo the changes, tap the value in the center of the color circle.
- > To modify the brightness of the colors, move the slider (3).

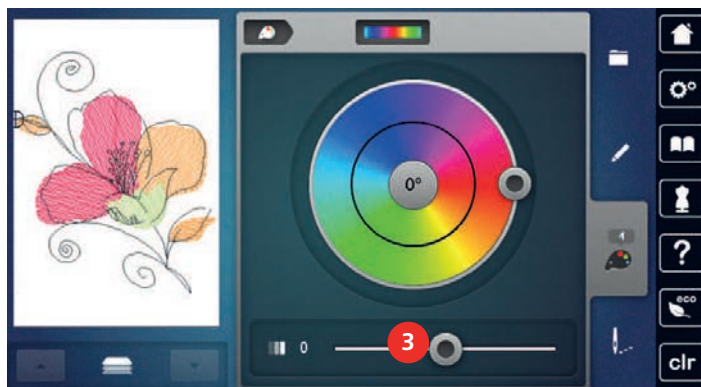

- > Tap «Edit».
 - The settings are applied, and the embroidery design can be seen in the new colors.

Changing the Thread Brand



- > Select the embroidery design.
- > Tap «Color Information».



- > Tap «Altering Color/Brand».
- > To display other thread brands, scroll to the left and to the right.



- > Tap «Assign Thread Brand».
 - Any thread colors of the selected embroidery design will be matched with the selected thread brand.

15.10 Embroidering the Embroidery Design

Overview Embroidery menu

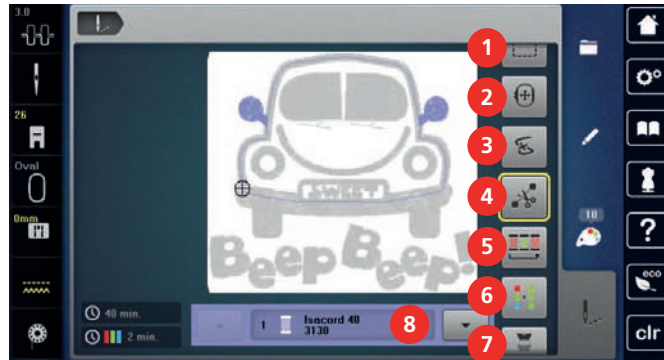

- | | | | |
|---|-------------------------------|---|--|
| 1 | «Basting» | 5 | «Reduce Color Changes» |
| 2 | «Moving the Hoop» | 6 | «Multi-colored Embroidery Design On/Off» |
| 3 | «Embroidery Sequence Control» | 7 | «Endless Embroidery» |
| 4 | «Cut Connecting Stitches» | 8 | «Color Indication» |

Adding Basting Stitches

The basting stitches can be embroidered along the embroidery design. As a result, the fabric and the stabilizer are better fixed together.

- > Select the embroidery design.
- > Tap «Embroidery».



- > To embroider the basting stitches along an embroidery design, tap «Basting».
- > To embroider the basting stitches along the hoop, tap «Basting» again.
- > To deactivate the basting stitches, tap «Basting» again.

Moving the Hoop

If the embroidery design is so big that repeated rehooping is necessary, the embroidered design can be moved again.

- > Select the embroidery design.
- > Tap «Embroidery».



- > Tap «Moving the Hoop».
- > Turn the «Upper Multi-function Knob» to move the embroidery design horizontally.
- > Turn the «Lower Multi-function Knob» to move the embroidery design vertically.



- > To accept the settings, tap «Embroidery» in the Process Navigation.

Embroidery sequence control when thread breaks

If the thread breaks, the needle can be repositioned in the embroidery design using the function Embroidery Sequence Control.

- > Select the embroidery design.
- > Tap «Embroidery».



- > Tap «Embroidery Sequence Control».
 - A compact view of the embroidery design appears on the left side of the display. On the right side the embroidery design is shown in enlarged view.

- > Select the desired position in the compact view.
- > To move the hoop stitch by stitch, turn the «Upper Multi-function Knob».
- > To move the hoop in large steps, turn the «Lower Multi-function Knob».
 - The number in the yellow-outlined icon indicates the number of stitches within the embroidery sequence.



- > To select the desired stitch by entry, tap the icon «Stitch Position via Number».

Cutting Connecting Stitches

The function is activated as standard and the connection stitches are automatically cut. If the function is deactivated, the connection stitches must be cut by hand.

- > Select the embroidery design.
- > Tap «Embroidery».



- > To switch off the function, tap «Cut Connecting Stitches».
- > To switch on the function, tap «Cut Connecting Stitches» again.

Reducing Color Changes

When the embroidery designs overlap, the color changes **cannot** be reduced.

- > Select the embroidery design.
- > Tap «Embroidery».



- > Tap «Reduce Color Changes».
 - Identical colors of the embroidery design are collected to one color.

Multi-colored Embroidery Design On/Off

Multi-colored embroidery designs can also be embroidered in one color.

- > Select the embroidery design.
- > Tap «Embroidery».



- > Tap «Multi-colored Embroidery Design On/Off».
 - The embroidery design is embroidered in one color.

Endless Embroidery

This makes it possible to embroider trims that have already been started, even if the machine has been switched off and on.

Prerequisite:

- A trim embroidery design must be saved on a separate storage medium. The reference points must be included in the embroidery design.

- > Select trim embroidery designs from the separate storage medium.
- > Tap «Embroidery».





- > Tap «Endless Embroidery».

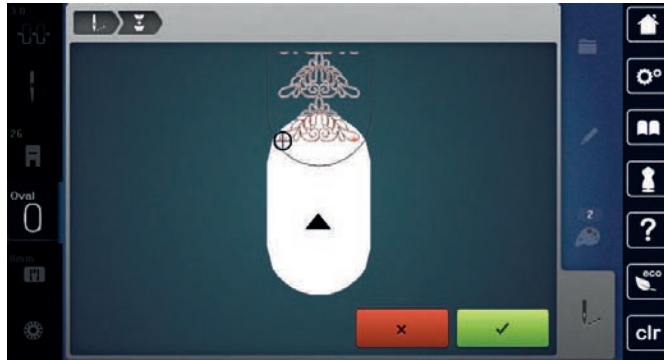

- > Remove the hoop and spin the fabric in such a way that the embroidered reference points are in the upper embroidery field of the hoop and the reference points are located at least 3 cm (1.18 inch) away from the upper edge of the hoop.
- > Attach the hoop.
- > Tap «Confirm».
 - The hoop is automatically moved close to the last stitch.
 - The icon «AUTO» is active and the hoop automatically moves close to the last reference point.
- > Use the arrow icons to determine the side of the embroidered section on which you want to position the next reference point.
- > To position the embroidery hoop precisely, turn the «Upper Multi-function Knob» or the «Lower Multi-function Knob».

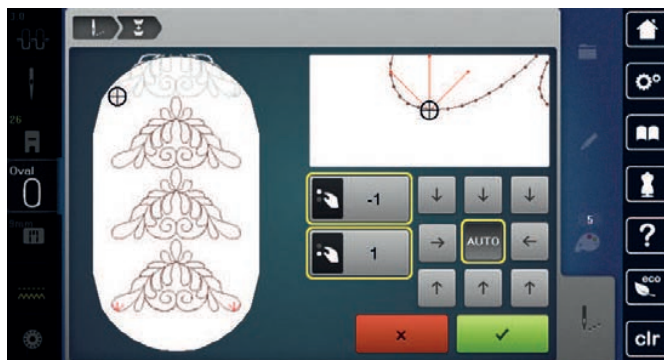

- > Tap «Confirm».



- > Press the button «Start/Stop» and continue embroidering.
- > Repeat these steps until the required length of the trim has been achieved.

Color Indication

Every color of the embroidery design can be selected individually. The hoop moves to the first stitch of the current color. The currently active color can be embroidered individually or in another sequence.



- > Select the embroidery design.
- > Tap «Embroidery».
- > Touch the icon Scroll up to select the previous color of the embroidery design.

15.11 Frearm Embroidery

Free arm embroidering is defined as embroidering tubular fabrics or garments which are positioned around the free arm of the embroidery machine while being embroidered. Often used with sleeves, pant legs or other narrow-tailored garments.



A fabric tube can be conveniently placed around the freearm of the machine if the embroidery hoop is moved to the left into the park position before attaching or removing it. To return the hoop to the embroidery position afterwards, push the button «Start/Stop».

If possible, use a full bobbin as the embroidery hoop must be removed when the bobbin is changed.

Borders can be closed easily and exactly along the edge of the tube to form a ring. Before working out the last embroidery design, after rehooping the fabric, activate the function «Pinpoint Placement» in the Edit Mode. Use the sub-function «Free Point Positioning» to insert the missing embroidery design for a perfect fit.

The movability of the embroidery arm can be limited or impeded with very narrow tubes. Therefore please make sure that the embroidery hoop can move forwards and backwards sufficiently. An impediment of the embroidery arm caused by a tube which is too tight can result in embroidery design offset or in damaging the fabric.

Check the Movability of the Freearm

Please note: With tiny fabric tubes, deactivate the thread-away in the Setup Program if necessary.

- > Open the embroidery design on the machine and edit as desired.
- > Mark the embroidery design position and the size on the fabric in a suitable way.
- > Select the embroidery hoop as small as possible.
- > Hoop or stick the fabric along with the appropriate stabilizer in the embroidery hoop, depending on the stabilizer.
- > Pull the fabric tube carefully over the freearm of the machine and attach the embroidery hoop at the clutch of the embroidery module.
- > If necessary, reposition the embroidery design.
- > Tap «Check Embroidery Design Size».
- > After the successful check of the embroidery design size, start the embroidery process.



15.12 Administering Embroidery Designs

Administering Embroidery Designs

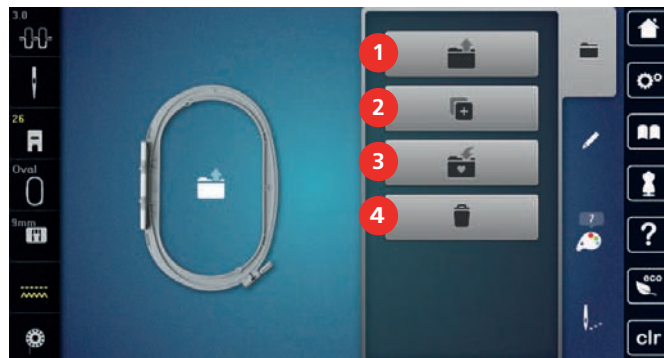



- | | | | |
|---|---------------------------------|---|---------------------------------|
| 1 | «Loading the Embroidery Design» | 3 | «Save Embroidery Design» |
| 2 | «Adding an Embroidery Design» | 4 | «Deleting an Embroidery Design» |

Saving Embroidery Designs in the Personal Memory





In the file «Save Embroidery Designs» any embroidery designs including individually edited embroidery designs can be saved.

- > Select the embroidery design.
- > Edit the embroidery design.
- > Tap «Selection».







-  > Tap «Save Embroidery Design».
 - The embroidery design to be saved is outlined in yellow.
-  – The «Embroidery Machine» is activated.
-  > Tap «Confirm».





Saving the Embroidery Design on the BERNINA USB Stick

- > Select the embroidery design.
- > Edit the embroidery design.
-  > Tap «Selection».
-  > Tap «Save Embroidery Design».
 - The embroidery design to be saved is outlined in yellow.
- > Insert the BERNINA USB stick into the USB port of the machine.
-  > Tap «USB Stick».
-  > Tap «Confirm».

Overwriting the Embroidery Design in the Personal Memory



- > Select the embroidery design.
- > Edit the embroidery design.
-  > Tap «Selection».
-  > Tap «Save Embroidery Design».
 - The embroidery design to be saved is outlined in yellow.
-  – The «Embroidery Machine» is activated.
- > Select the embroidery design which is to be overwritten.
-  > Tap «Confirm».

Overwriting the Embroidery Design on the BERNINA USB Stick

- > Select the embroidery design.
- > Edit the embroidery design.
-  > Tap «Selection».
-  > Tap «Save Embroidery Design».
 - The embroidery design to be saved is outlined in yellow.
- > Insert the BERNINA USB stick into the USB port of the machine.
-  > Tap «USB Stick».
- > Select the embroidery design which is to be overwritten.
-  > Tap «Confirm».

Importing Stitch Patterns

Stitch patterns or stitch pattern combinations can be imported from sewing mode into embroidery mode and edited like embroidery designs. For example, border designs can be quickly and easily created and saved as embroidery designs in the folder «Personal embroidery designs».

-  > Tap «Home».
-  > Tap «Sewing Mode».
- > Select the stitch pattern.



> Tap «Home».



> Tap «Embroidery Mode».
– The stitch pattern is automatically stored in the folder «Personal Embroidery Design».



> Select «Personal Embroidery Design».
> Select the stitch pattern.

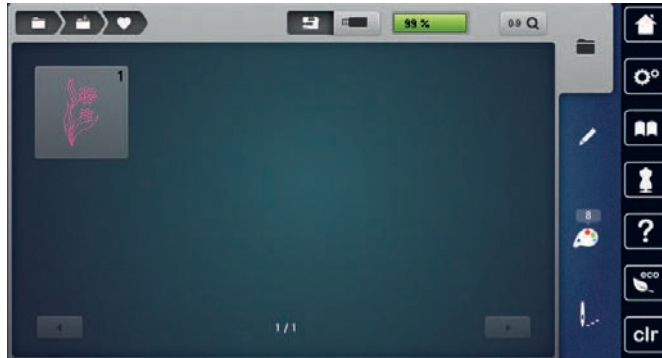

Loading an Embroidery Design from the Personal Memory



> Tap «Selection».



> Tap «Loading the Embroidery Design».



> Select «Personal Embroidery Design».
> Select the embroidery design.

Loading an Embroidery Design from the BERNINA USB Stick



> Tap «Selection».
> Insert the BERNINA USB stick into the USB port of the machine.



> Tap «Loading the Embroidery Design».



> Tap «USB Stick».
> Select a personal embroidery design.

Deleting an Embroidery Design from the Personal Memory

The embroidery designs which are saved in the personal memory can be deleted individually.



> Tap «Selection».



> Tap «Deleting».



– The «Embroidery Machine» is activated.

> Select the embroidery design which is to be deleted.



> Tap «Confirm».

Deleting an Embroidery Design from the BERNINA USB Stick



> Tap «Selection».





> Tap «Deleting».
> Insert the BERNINA USB stick into the USB port of the machine.

16 Embroidery

16.1 Embroidering via the button «Start/Stop»

In case of a power cut the embroidery process is interrupted. After the restart the machine goes to the position which was embroidered last.

- 
 - > Push the button «Start/Stop» until the embroidery machine starts.
 - All parts of the design being in the current color are embroidered.
 - The embroidery machine stops automatically at the end.
 - Both threads are cut automatically.
 - The embroidery machine switches to the next color automatically.
- 
 - > Change the upper thread.
 - > To embroider the new color, push the button «Start/Stop».
 - > After completing the embroidery design, finish the embroidering process by tapping the icon «Completing the Embroidering Process» (1) or embroider the embroidery design again as trim by tapping the icon «Endless Embroidery» (2).

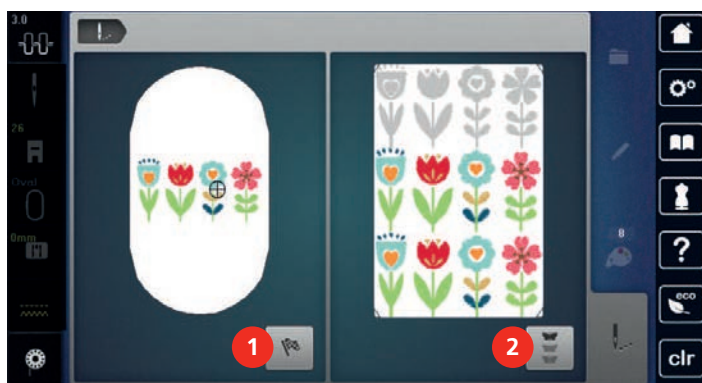

16.2 Increasing the Embroidery Speed

To ensure the best embroidery quality, the speed when embroidering is reduced depending on the embroidery position. Choose between the two options to either embroider at optimal or maximum speed. Standard = optimal speed. It has to be considered that the quality of the embroidered embroidery design at maximum speed cannot be ensured.

By switching the machine off and on, the optimal embroidery speed is activated.

Prerequisite:

- Embroidering has started.
- 
 - > Tap «Embroidery Speed».
 - The maximum speed is activated.
 - > Tap «Embroidery Speed» again.
 - The optimal speed is activated.

16.3 Adjusting the upper thread tension

The default setting of the upper thread tension is set automatically as soon as a stitch pattern or an embroidery motif is selected.

When of using other types of sewing or embroidery threads, the optimal tension may vary. Therefore it may be necessary to adjust the upper thread tension according to the sewing or embroidering project as well as the desired stitch pattern or the embroidery motif individually.

The higher the upper thread tension, the tighter the upper thread which means that the bobbin thread is pulled up to the top of the fabric. When the upper thread tension is low, the upper thread is less tightened which means that the bobbin thread is pulled up less.

17 Care and Maintenance

17.1 Firmware

Checking the firmware version

The firmware and hardware versions of the machine and the connected embroidery module are displayed.



> Tap «Setup Program».



> Tap «Machine settings».



> Tap «Information».



> Tap «Machine Data».

Updating firmware



The machine's current firmware and detailed step-by-step instructions for the update process can be downloaded from www.bernina.com. In general, personal data and settings are automatically transferred during a firmware update. For reasons of safety, it is also recommended to save data and settings on a BERNINA USB stick before the firmware update is started. If personal data and settings should get lost during a firmware update, they can be transferred to the machine again afterwards.

Prerequisite:

- Accessories such as the Embroidery module or the BSR Foot which are connected to the machine have been removed.

> Insert the USB stick with the new firmware version into the machine.



> Tap «Setup Program».



> Tap «Machine settings».



> Tap «Maintenance/update».



> Tap «Updating firmware».



> To start the firmware update, tap «Update».

Please note: The update can take several minutes. During the update, do not switch the machine off and do not remove the USB stick.

- The machine restarts. Once the update is complete, a message appears.

Recovering saved data

If personal data and settings after a software update are not available anymore, they can be transferred to the machine again afterwards.

> Insert the BERNINA USB stick providing the saved data and settings into the USB port of the machine.



> Tap «Setup Program».



> Tap «Machine settings».



- > Tap «Maintenance/update».



- > Tap «Updating firmware».

NOTICE

BERNINA USB Stick (Optional Accessory) has been removed too early

Saved data cannot be transferred and the machine cannot be used.

- > Remove the BERNINA USB stick (optional accessory) only after the saved data has been transferred successfully.



- > Tap «Load Data».
 - After the data has been transferred, a green tick is temporarily displayed.

17.2 Machine**Cleaning the Display**

- > Clean the display when it is switched off with a soft slightly damp microfiber cloth.

Cleaning the Feed Dog

Remaining threads under the stitch plate must occasionally be removed.

- > Raise the needle and presser foot.

CAUTION**Electronically Driven Components**

Risk of injury near the needle and the hook.

- > Switch the machine off and disconnect it from the power supply system.

- > Remove the needle and presser foot.
- > Lower feed dog.



- > Remove the stitch plate.

NOTICE**Dust and Thread Residues Inside the Machine**

Damage to mechanical and electronic components.

- > Use a brush or a soft cloth.
- > Do not use compressed air spray.

- > Clean the feed dog with the brush.

Cleaning the Hook

CAUTION

Electronically Driven Components

Risk of injury near the needle and the hook.

> Switch the machine off and disconnect it from the power supply system.

- > Open the hook cover.
- > Remove the bobbin case.
- > Push the release bracket to the left.



- > Flap down the fastening bracket along with the black hook race cover.
- > Remove the hook.

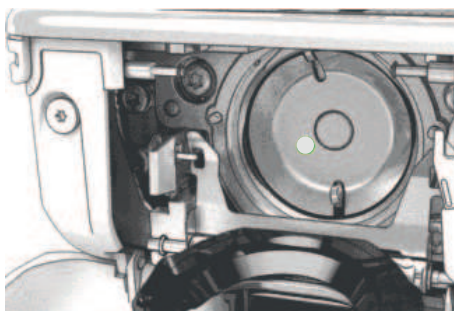

NOTICE

Dust and Thread Residues Inside the Machine

Damage to mechanical and electronic components.

- > Use a brush or a soft cloth.
- > Do not use compressed air spray.

- > Clean the hook race area with a brush and a soft cloth. Never use any sharp instruments.
- > Hold the hook at the pin in the center with two fingers.
- > Guide the hook with the lower edge diagonally from the top to the bottom behind the hook race cover.
- > Position the hook so that the two lugs on the hook driver fit into the corresponding openings on the hook, and the colored marking on the hook driver is visible in the hole of the hook.
- > Insert the hook.
 - The hook is magnetic and therefore fastened to the correct position.
- > Close the hook race cover and the fastening bracket until the release bracket engages.
- > As a check, turn the handwheel.
- > Insert the bobbin case.

Lubricating the Hook

By oiling the hook, the occurrence of unwanted noises in the hook area can be avoided. BERNINA recommends oiling the hook at the following intervals:

- Before using the machine for the first time
- After a longer downtime of the machine
- For intensive use: Daily before sewing
- When the message " Lubricate the Machine " is displayed
- In case of unwanted noises in the hook area

CAUTION**Electronically Driven Components**

Risk of injury near the needle and the hook.

- > Switch the machine off and disconnect it from the power supply system.

- > Remove the bobbin case.
- > Push the release bracket to the left.



- > Flap down the fastening bracket along with the black hook race cover.
- > Remove the hook.

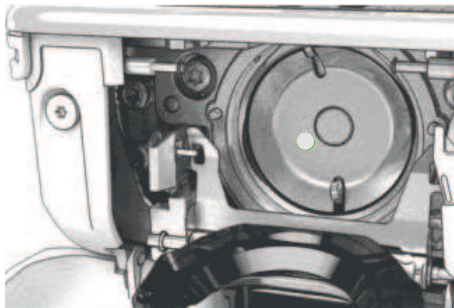

- > Clean the hook race area with a brush and a soft cloth. Never use any sharp instruments.
- > Add one drop of BERNINA oil down into the hook race.



- > Add one drop of oil into each of the two oil depots so that the felts are damp, and make sure that the red-marked surface of the hook sleeve remains free of oil.



- > Hold the hook at the pin in the center with two fingers.
- > Guide the hook with the lower edge diagonally from the top to the bottom behind the hook race cover.
- > Position the hook so that the two lugs on the hook driver fit into the corresponding openings on the hook, and the colored marking on the hook driver is visible in the hole of the hook.
- > Insert the hook.
 - The hook is magnetic and therefore fastened to the correct position.

- > Close the hook race cover and the fastening bracket until the release bracket engages.
- > As a check, turn the handwheel.
- > Insert the bobbin case.
- > Sew or embroider on a test fabric.

Cleaning the thread catcher



- > Tap «Setup Program».



- > Tap «Machine settings».



- > Tap «Maintenance/update».







- > Tap «Cleaning the Thread Catcher».
- > Clean the thread catcher according to the instructions on the display.



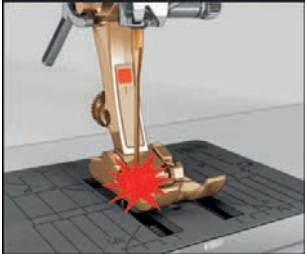

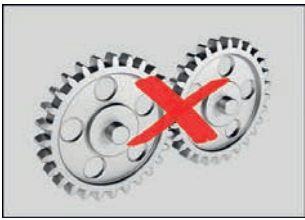
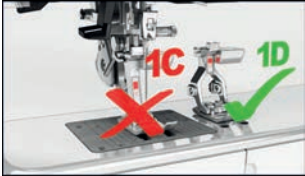
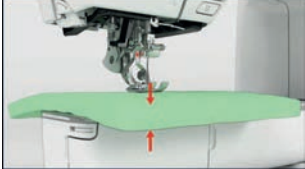
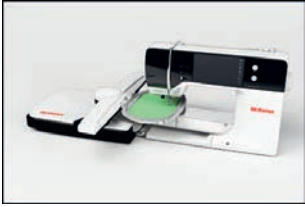
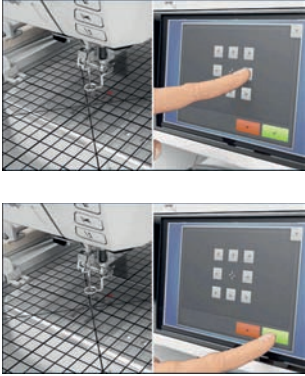

18 Errors and Faults

18.1 Error messages

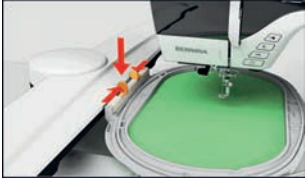
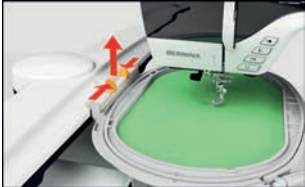
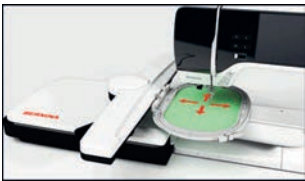
Message on the Display	Cause	Solution
	Stitch number unknown.	> Check the entry and enter the new number.
	Selection of stitch patterns not possible in Combi-mode.	> Combine other stitch patterns.
	The feed dog is not lowered.	> Push the button «Feed Dog Up/Down» to lower the feed dog.
	The selected needle and stitch plate cannot be used in combination.	> Replace the needle. > Replace the stitch plate.
	The needle is not at its top end.	> Adjust the needle position via the handwheel.
	The upper thread is used up.	> Rethread.
	The upper thread has broken.	> Rethread.
	The bobbin thread is used up.	> Rethread.
	The bobbin thread has broken.	> Clean the hook. > Rethread.

Message on the Display	Cause	Solution
	<p>The main motor is not running.</p>	<ul style="list-style-type: none"> > Turn the handwheel clockwise until the needle is at its top position. > Remove the sewing project. Do not pull on the fabric or the thread. > Remove the stitch plate. > Remove the thread remnants. > Clean the hook. > Remove the hook and make sure that there are no pieces of broken needle points on the magnetic back of the hook. > Insert the hook correctly.
	<p>Incorrect presser foot for the BERNINA Dual Feed.</p>	<ul style="list-style-type: none"> > Fit a presser foot with the designation «D».
	<p>The fabric under the presser foot is too thick.</p>	<ul style="list-style-type: none"> > Reduce the fabric thickness.
	<p>The contact between the machine and the embroidery module is interrupted as a result of vibrations.</p>	<ul style="list-style-type: none"> > Make sure that the embroidery module and the machine are standing on a stable, even surface. > Connect the embroidery module to the machine.
	<p>The needle position doesn't correspond with the center of the hoop.</p>	<ul style="list-style-type: none"> > Calibrate the hoop.
	<p>The embroidery module is not attached.</p>	<ul style="list-style-type: none"> > Connect the embroidery module to the machine. > Contact the specialized BERNINA dealer to have the machine checked.

Message on the Display	Cause	Solution
	The hoop is not attached.	> Attach the hoop.
	The hoop is attached.	> Remove the embroidery hoop.
	The movement of the hoop follows.	> Tap «Confirm».
	The embroidery design is partly outside the hoop.	> Reposition the embroidery design and start embroidering it again.
	The embroidery design is too large.	> Reduce the size of the embroidery design. > Attach a larger hoop.
Not enough free capacity on the BERNINA USB stick (optional accessory).	There is not enough free capacity on the BERNINA USB stick (optional accessory).	> Make sure that the BERNINA USB stick (optional accessory) is used. > Delete data from the BERNINA USB stick (optional accessory).
No personal data on the BERNINA USB stick (optional accessory).	No personal data for recovery available on the BERNINA USB stick (optional accessory).	> Make sure that the data and settings have been saved on the BERNINA USB stick (optional accessory).
The recovery of personal data has failed.	The firmware update has been successful but the personal data could not be recovered.	> Make sure that the data and settings have been saved on the BERNINA USB stick. > Transfer saved data to the machine.

Message on the Display	Cause	Solution
No BERNINA USB stick is inserted. Make sure that the same BERNINA USB stick remains connected during the entire automatic update process.	The BERNINA USB stick (optional accessory) is not inserted.	<ul style="list-style-type: none"> > Use a BERNINA USB stick (optional accessory) which provides enough free capacity.
The firmware update has failed.	The latest firmware version cannot be found on the USB stick.	<ul style="list-style-type: none"> > Make sure that the compressed zip file has been unzipped for the firmware update. > Check whether the data for the software update is saved directly on the data medium and not in a file on the USB stick. > Updating Firmware.
	The machine must be cleaned/lubricated.	<ul style="list-style-type: none"> > Clean the machine. > Lubricate the machine. <p>Important Information on Lubricating:</p> <ul style="list-style-type: none"> > Too much oil may stain the fabric and the thread. > After lubricating, sew/embroider a test piece first.
The automatic thread cutter (at the thread catcher) needs cleaning.	The automatic thread cutter needs cleaning. The message appears every time when the machine is started as soon as 1000 cutting cycles have been carried out.	<ul style="list-style-type: none"> > Tap «Confirm». <ul style="list-style-type: none"> – The machine calls up the function «Clean the thread catcher». > Clean the thread catcher according to the instructions on the display. <ul style="list-style-type: none"> – The counter for the cutting cycles is reset.
It is time for the regular maintenance. Please contact your authorized BERNINA dealer to make an appointment.	<p>The machine needs maintenance. The message appears after the programmed service interval has expired.</p> <p>Important Information: Having your machine cleaned and serviced properly at the appropriate times ensures its proper functioning and a long service life. In case of non-compliance, the service life may be negatively affected and the warranty service may possibly become limited. The cost allocation for maintenance work is regulated nationally. Consult your authorized BERNINA dealer or your service center for more details.</p>	<ul style="list-style-type: none"> > Contact an authorized BERNINA dealer. > Delete the message temporarily by touching the icon «ESC». <p>After the third deletion, the message is not displayed until the next service interval is reached.</p>

Message on the Display	Cause	Solution
	<p>The calibration of the Buttonhole Foot with Slide #3A has failed.</p>	<ul style="list-style-type: none"> > Check the presser foot for ease of movement. If necessary, remove lint, dust and fabric remnants. > Clean the reflector with a soft, slightly damp microfiber cloth. > Check the position of the reflector. If necessary, correct the position of the reflector or replace the presser foot. > Check the plastic on the underside of the presser foot for signs of wear. If necessary, replace the presser foot. > Clean the feed dog. > If the error still occurs, contact your authorized BERNINA dealer.
#1000	The needle threader is jammed.	<ul style="list-style-type: none"> > Switch off the machine. Press the needle threader down and release it again. Switch the machine on. > If the error still occurs, contact your authorized BERNINA dealer.
#1001	The button «Thread Cutter» is stuck or defective.	<ul style="list-style-type: none"> > Make sure that the button can be operated without restriction. > If the error still occurs, contact your authorized BERNINA dealer.
#1002	The button «Needle position Up/Down» is stuck or defective.	<ul style="list-style-type: none"> > Make sure that the button can be operated without restriction. > If the error still occurs, contact your authorized BERNINA dealer.
#1003	The button «Start/Stop» is stuck or defective.	<ul style="list-style-type: none"> > Make sure that the button can be operated without restriction. > If the error still occurs, contact your authorized BERNINA dealer.
#1004 #1005 #1010	The exact cause of the malfunction cannot be determined.	<ul style="list-style-type: none"> > Restart the machine. > If the error still occurs, contact your authorized BERNINA dealer.

18.2 Troubleshooting

Fault	Cause	Solution
Uneven stitch formation	Upper thread too tight or too loose.	<ul style="list-style-type: none"> > Adjust the upper thread tension. > Check the thread feed from the thread spool.
	Needle blunt or bent.	> Replace the needle, make sure that a new BERNINA quality needle is used.
	Poor quality needle.	> Use a new BERNINA quality needle.
	Poor quality thread.	> Use quality thread.
	Incorrect needle/thread combination.	> Match the needle with the thread size.
	Incorrectly threaded.	> Rethread.
	Fabric was pulled.	> Feed the fabric evenly.
Uneven stitch formation	Incorrect bobbin case is used.	> Use the supplied bobbin case marked with the triangle.
		
Skipped stitches	Incorrect needle.	> Use the needle system 130/705H.
	Needle blunt or bent.	> Replace the needle.
	Poor quality needle.	> Use a new BERNINA quality needle.
	The needle is incorrectly inserted.	> Insert the needle with the flat side to the back as far up as it will go into the needle holder and tighten the screw.
	Incorrect needle point.	> Match the needle point to the texture of the material.
Faulty stitching	Thread remnants between the thread tension discs.	> Fold a piece of thin material and slide the folded edge (not the raw edges) between the thread tension discs.
	Incorrectly threaded.	> Rethread.
	Thread remnants below the bobbin case spring.	> Remove the thread remnants under the spring.

Fault	Cause	Solution
Upper thread breaks	Incorrect needle/thread combination.	> Match the needle with the thread size.
	Upper thread is too tight.	> Reduce the upper thread tension.
	Incorrectly threaded.	> Rethread.
	Poor quality thread.	> Use quality thread.
	The stitch plate or the hook tip is damaged.	> Contact the nearest specialized BERNINA dealer to have the damages repaired. > Replace the stitch plate.
	The thread is caught in the area of the thread take-up lever.	> Remove the screw (1) on the headframe with the angular Torx Screwdriver. > Pull the headframe at the bottom slightly forward. > Flip the headframe upwards a bit and remove it. > Remove the thread remnants. > Attach the headframe and tighten the screw.
		
Lower thread breaks	The bobbin case is damaged.	> Replace the bobbin case.
	The stitch hole in the stitch plate is damaged.	> Contact the nearest specialized BERNINA dealer to have the damages repaired. > Replace the stitch plate.
	Needle blunt or bent.	> Replace the needle.
Needle breaks	The needle is incorrectly inserted.	> Insert the needle with the flat side to the back as far up as it will go into the needle holder and tighten the screw.
	Fabric was pulled.	> Feed the fabric evenly.
	Thick fabric has been pushed.	> Use a suitable presser foot, e. g. Jeans Foot #8, for thick fabric. > Use the height compensating tool when sewing over a thick seam.
	Knotted thread.	> Use quality thread.
Display is inactive	Incorrect calibrating data.	> Recalibrate the display. (see page 57) > If calibration cannot be selected in the Setup Program, switch the machine on again while simultaneously pushing and holding the buttons «Needle Position Right/Left».
	The eco Mode is active.	> Tap «eco Mode».

Fault	Cause	Solution
Stitch width not adjustable	The selected needle and stitch plate cannot be used in combination.	<ul style="list-style-type: none"> > Replace the needle. > Replace the stitch plate.
	The «Presser Foot Indicator/Presser Foot Selection» prevents the adjustment of the stitch width.	<ul style="list-style-type: none"> > Select the attached presser foot.
Speed too low	Unfavorable room temperature.	<ul style="list-style-type: none"> > Place the machine in a warm room one hour before use.
	Settings in the Setup Program.	<ul style="list-style-type: none"> > Adjust the sewing speed in the Setup Program. > Adjust the slide.
The machine doesn't start	Unfavorable room temperature.	<ul style="list-style-type: none"> > Place the machine in a warm room one hour before use. > Connect the machine and switch it on.
	The machine is damaged.	<ul style="list-style-type: none"> > Contact an authorized BERNINA dealer.
The light of the button «Start-/Stop» doesn't light up	Light is defect.	<ul style="list-style-type: none"> > Contact an authorized BERNINA dealer.
Neither the sewing light nor the light on the freearm lights up	Settings in the Setup Program.	<ul style="list-style-type: none"> > Activate it in the Setup Program.
	The sewing light is defect.	<ul style="list-style-type: none"> > Contact an authorized BERNINA dealer.
Upper thread indicator fails to respond	Settings in the Setup Program.	<ul style="list-style-type: none"> > Activate it in the Setup Program.
	The upper thread indicator is defect.	<ul style="list-style-type: none"> > Contact an authorized BERNINA dealer.
Bobbin thread indicator doesn't react	Settings in the Setup Program.	<ul style="list-style-type: none"> > Activate it in the Setup Program.
	The bobbin thread indicator is defect.	<ul style="list-style-type: none"> > Contact an authorized BERNINA dealer.
Error during firmware update	USB stick is not recognized.	<ul style="list-style-type: none"> > Use the BERNINA USB stick.
	The update process is blocked and the hourglass on the display is inactive.	<ul style="list-style-type: none"> > Remove the USB stick. > Switch off the machine. > Switch the machine on. > Follow the instruction on the display.
	Firmware update files are not found.	<ul style="list-style-type: none"> > Unzip the update data. > Store data for the firmware update directly on the data medium and not in a folder on the USB stick.
BSR Presser Foot #42 not detected	Lens is dirty.	<ul style="list-style-type: none"> > Clean the lens with a soft, slightly damp cloth.
	BSR cable not inserted correctly.	<ul style="list-style-type: none"> > Insert the BSR connector vertically until it can be felt to click into place.
Beads and/or bartacks are repeatedly not sewn properly	The Buttonhole Foot with Slide #3A is not calibrated with the machine.	<ul style="list-style-type: none"> > Calibrate Buttonhole Foot with Slide #3A. (see page 59)

19 Storage and Disposal

19.1 Storing the Machine

It is recommended to store the machine in the original packaging. If the machine is stored in a cold room, place it in a warm room one hour before use.

- > Switch the machine off and disconnect it from the power supply.
- > Don't store the machine outdoors.
- > Protect the machine against climatic influences.

19.2 Dispose of the Machine

- > Clean the machine.
- > Sort the components by their materials and dispose of them according to the local laws and regulations.

20 Technical data

Designation	Value	Unit
Maximum fabric thickness	12.5 (0.49)	mm (in)
Sewing light	30	LED
Maximum speed	1000	Stitches per minute
Measurements without the spool pin (W × H × D)	522 × 358 × 214 (20.55 × 14.09 × 8.43)	mm (in)
Weight	14 (30.86)	kg (lb)
Energy consumption	140	W
Input voltage	100 – 240	V
Protection class (Electrical engineering)	II	

21 Overview Stitch Patterns

21.1 Overview Stitch Patterns

Practical Stitches

1	2	3	4	5	6	7	8	9	10	11	12	13	14
15	16	17	18	19	20	21	22	23	24	25	26	27	29
31	32	33	34										

Buttonholes

51	52	53	54	55	56	57	58	59	60	61	62	63	66
68	69												

Decorative Stitches

Nature Stitches

101	102	103	104	107	108	110	111	112	113	114	115	117	119
122	123	124	125	129	133	134	136	137	140	141	143	144	145
146	147	148	150	152	156	158	159	160	170	171			

Nature Stitches with Sideways Motion

201	204	206	207	212	230	231	232	233	234	235	236	237	238
239	240	242	243	244	245	246	247	248	249	250	251	252	257

Cross Stitches

301	302	303	304	305	306	307	308	309	311	313	314	316	317
321	322	323	324	325	326	327	328	332	333	334	335	336	337
338	339	371	372	373	374	375	376	377					

Satin Stitches

401	402	405	406	407	408	412	413	414	415	416	417	419	422
423	424	425	426	427	428	429	430	431	434	437	439	441	443
444	445	446	447	448	450	451	457	458	461	464	465	466	467
468	469	470	471	473									

Satin Stitches with Sideways Motion

501	502	505	506	507	508	509	510	511	512	513	514	517	518
519	520	523	524	525									

Geometric Stitches

601	602	603	604	605	606	607	608	609	610	611	612	613	614
615	616	618	619	621	622	623	624	625	626	627	628	629	630
631	633	635	636	637	639	640	641	642	643	644	646	648	649



651	652	653	654	655	656	657	658	660	661	662	663	664	665
666	671	672	674	675	676	677	679	680	681	682	683	684	685
686	690	692	696										

White Embroidery

701	702	704	705	706	707	708	709	710	711	712	713	714	717
718	719	720	721	722	723	724	725	726	727	728	730	731	732
734	735	736	737	738	739	740	741	742	743	745	746	747	748
749	750	751	753	756	757	761	763	765	767	769	770	777	779
780	781												

White Embroidery with Sideways Motion

801	802	827	828	829	830	833	834	835	840	841
-----	-----	-----	-----	-----	-----	-----	-----	-----	-----	-----

Children Stitches

902	903	904	906	910	913	914	916	919	920	921	930	933	934
935	936	937	938	939	940	941	942	943	944	945	946	947	948

Children Stitches with Sideways Motion

1001	1002	1003	1004	1005	1006	1007	1008
------	------	------	------	------	------	------	------

Filigree Stitches with Sideways Motion

1201	1202	1203	1204	1205	1206	1207	1208	1209	1210	1211	1212	1213	1215
1216	1217	1218	1220	1221									

Tapering Stitches

1401	1402	1403	1404	1405	1406	1409	1411	1412	1413	1414	1415	1416	1417
1418	1419	1420	1422	1423	1424	1430	1431	1446	1447	1448	1450	1460	1462

Skyline Stitches (Special Stitches)

1501 SWISS	1502 RUBEN	1503 ESPANA	1504 LONDON	1505 AUSTRALIA	1507 AFRICA	1508 NEW ZEALAND	1509 TOKYO	1510 DELHI	1511 EGYPT	1512 INDONESIA	1513 JAPAN	1514 YOU	1515 BERLIN
1516 MEXICO	1517 PARIS	1518 GERMANY	1519 USA	1520 ROMA	1521 SOUTH AFRICA	1522 GREECE	1524 SCANDINAVIA	1526 USA	1527 BRAZIL				

Quilt Stitches with Sideways Motion

1601	1602	1603	1604	1605	1606	1607	1608	1609	1610	1611	1612	1613	1614
1615	1616	1617	1618	1619	1620	1629	1630	1631	1632	1633	1634	1635	1636
1657	1658	1659	1660										

International

1701	1702	1703	1704	1705	1706	1707	1708	1709	1710	1711	1715	1716	1717
1718	1719	1720	1721	1722	1723								

Quilt Stitches

1324	1325	1326	1327	1328	1329	1330	1331	1332	1333	1334	1335	1337	1338
1339	1340	1341	1342	1343	1344	1345	1347	1348	1350	1351	1352	1353	1354
1355	1356	1357	1358	1359	1395	1396	1397	1398					

21.2 Overview Embroidery Desings

Editing the Embroidery Design

Let your creativity run free. A vast selection of embroidery designs is at your disposal.

If you see one of the following pictograms below a number of the embroidery design, you can find additional information at



























<https://www.bernina.com/specialeffects>.

	Detached Point		PunchWork
	Basic CutWork		Couching
	Fringe Embroidery		Projects in the Hoop
	Appliqué		Puffy Fonts
	CutWork		Quilting
	PaintWork		Trapunto
	CrystalWork		











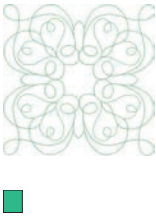

Embellishment



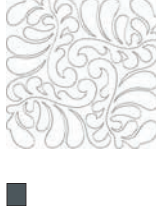









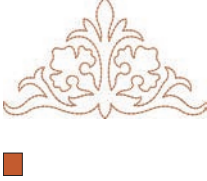

No.	Embroidery Design Colors	Width × height • mm • (in)	No.	Embroidery Design Colors	Width × height • mm • (in)
BE790501		199 × 276 (7.9 × 10.9)	21008-15		119 × 120 (4.7 × 4.7)

No.	Embroidery Design Colors	Width × height • mm • (in)	No.	Embroidery Design Colors	Width × height • mm • (in)
82006-30 	 	100 × 174 (3.9 × 6.9)	BE790503	 	130 × 130 (5.1 × 5.2)
BE790504	 	121 × 121 (4.8 × 4.8)	FB126	 	87 × 102 (3.4 × 4.0)
82005-01 	 	175 × 109 (6.9 × 4.3)	21003-26 	 	123 × 124 (4.8 × 4.9)
82006-36 	 	121 × 123 (4.8 × 4.8)	BE790403	 	140 × 130 (5.5 × 5.1)
NB018	 	90 × 97 (3.6 × 3.8)	NB728	 	97 × 112 (3.8 × 4.4)
NB403	 	78 × 78 (3.1 × 3.1)	HG079	 	116 × 116 (4.6 × 4.6)

No.	Embroidery Design Colors	Width × height • mm • (in)	No.	Embroidery Design Colors	Width × height • mm • (in)
FB457 	 	107 × 83 (4.2 × 3.3)	FQ881	 	129 × 129 (5.1 × 5.1)
FB336	 	122 × 122 (4.8 × 4.8)	FB377	 	121 × 92 (4.8 × 3.6)
FQ870	 	122 × 105 (4.8 × 4.1)	FB385	 	131 × 127 (5.2 × 5.0)
NB646	 	98 × 65 (3.9 × 2.6)	FQ072	 	79 × 101 (3.1 × 4.0)
NB101	 	99 × 99 (3.9 × 3.9)	NB373	 	121 × 176 (4.8 × 7.0)
WS649	 	125 × 248 (4.9 × 9.8)	NB708	 	137 × 127 (5.4 × 5.0)
FB433	 	121 × 121 (4.8 × 4.8)			

















Quilt motifs















No.	Embroidery motif Colors	Width × height • mm • (in)	No.	Embroidery motif Colors	Width × height • mm • (in)
BD289		201 × 201 (7.9 × 7.9)	BD285		202 × 201 (8.0 × 7.9)
BD288		202 × 201 (8.0 × 7.9)	BD292		94 × 95 (3.7 × 3.7)
BD299		94 × 95 (3.7 × 3.7)	BD308		95 × 94 (3.7 × 3.7)
BD413		97 × 97 (3.8 × 3.8)	BD837		123 × 123 (4.9 × 4.9)
12380-43		123 × 123 (4.9 × 4.9)	12380-30		89 × 96 (3.5 × 3.8)
12380-04		83 × 89 (3.3 × 3.5)	12380-08		89 × 89 (3.5 × 3.5)
12380-09		111 × 61 (4.4 × 2.4)	12380-22		110 × 60 (4.4 × 2.4)









No.	Embroidery motif Colors	Width × height • mm • (in)	No.	Embroidery motif Colors	Width × height • mm • (in)
12380-10		152 × 356 (6.0 × 14.0)	BD796		47 × 174 (1.9 × 6.9)
BD800		127 × 122 (5.0 × 4.8)	BD801		122 × 124 (4.8 × 4.9)
BD804		122 × 123 (4.8 × 4.9)	BD394		97 × 96 (3.8 × 3.8)
BD412		89 × 53 (3.5 × 2.1)	BD513		63 × 63 (2.5 × 2.5)
BD514		63 × 63 (2.5 × 2.5)	BD553		113 × 121 (4.5 × 4.8)
BD567		108 × 108 (4.3 × 4.3)	BD554		110 × 109 (4.3 × 4.3)
BD659		66 × 219 (2.6 × 8.6)	BD665		160 × 117 (6.3 × 4.6)

No.	Embroidery motif Colors	Width × height • mm • (in)	No.	Embroidery motif Colors	Width × height • mm • (in)
HE959	 ■	120 × 120 (4.8 × 4.8)			





















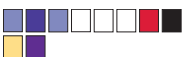







Borders and Lace

























No.	Embroidery Design Colors	Width × height • mm • (in)	No.	Embroidery Design Colors	Width × height • mm • (in)
NB952	 ■	108 × 119 (4.3 × 4.7)	OC00303 	 ■	100 × 110 (4.0 × 4.4)
12410-08 	 ■	80 × 168 (3.2 × 6.6)	12410-07 	 ■	115 × 158 (4.5 × 6.2)
12410-15 	 ■	29 × 133 (1.1 × 5.3)	12454-05 	 □ □ □ □	117 × 108 (4.6 × 4.3)
12454-06 	 □ □ □ □ □ □	116 × 47 (4.6 × 1.9)	12454-07 	 □ □ □ □ □	48 × 57 (1.9 × 2.3)
FA981	 ■	35 × 142 (1.4 × 5.6)	BE790701	 ■	113 × 230 (4.5 × 9.1)

No.	Embroidery Design Colors	Width × height • mm • (in)	No.	Embroidery Design Colors	Width × height • mm • (in)
BE790704		72 × 217 (2.9 × 8.6)	BE790703		70 × 186 (2.8 × 7.3)
BE790702		73 × 190 (2.9 × 7.5)	21013-29		40 × 152 (1.6 × 6.0)
21013-30		75 × 75 (3.0 × 3.0)	12398-29		26 × 153 (1.0 × 6.0)
12398-30		76 × 76 (3.0 × 3.0)	OC33411		24 × 177 (1.0 × 7.0)
CM471		59 × 190 (2.3 × 7.5)	FB403		52 × 208 (2.1 × 8.2)
FQ785		92 × 342 (3.6 × 13.5)	FQ969		51 × 162 (2.0 × 6.4)
FQ408		30 × 97 (1.2 × 3.8)	FQ736		8 × 253 (0.3 × 10.0)















No.	Embroidery Design Colors	Width × height • mm • (in)	No.	Embroidery Design Colors	Width × height • mm • (in)
BD582		48 × 171 (1.9 × 6.7)	NA912		15 × 115 (0.62 × 4.5)
NA914		18 × 120 (0.7 × 4.7)	NB478		121 × 85 (4.8 × 3.4)
FQ847		142 × 150 (5.6 × 5.9)	FQ945		93 × 95 (3.7 × 3.7)
FQ041		54 × 78 (2.1 × 3.1)	FB422		52 × 33 (2.1 × 1.3)
FB423		132 × 53 (5.2 × 2.1)			













Children











No.	Embroidery motif Colors	Width × height • mm • (in)	No.	Embroidery motif Colors	Width × height • mm • (in)
BE790305 	 	118 × 145 (4.7 × 5.7)	BE790302	 	68 × 66 (2.7 × 2.6)
BE790303	 	69 × 70 (2.7 × 2.8)	BE790304	 	127 × 65 (5.0 × 2.6)
BE790307 	 	141 × 127 (5.6 × 5.0)	BE790308 	 	191 × 219 (7.5 × 8.6)
12421-03	 	45 × 48 (1.8 × 1.9)	NB193	 	113 × 96 (4.5 × 3.8)
CM384	 	77 × 80 (3.1 × 3.2)	CM226 	 	63 × 63 (2.5 × 2.5)
CM193 	 	106 × 127 (4.2 × 5.0)	CM220 	 	71 × 71 (2.8 × 2.8)

No.	Embroidery motif Colors	Width × height • mm • (in)	No.	Embroidery motif Colors	Width × height • mm • (in)
WP325	 	77 × 94 (3.1 × 3.7)	CM428	 	78 × 106 (3.1 × 4.2)
CM404	 	47 × 165 (1.9 × 6.5)	CM368	 	70 × 140 (2.8 × 5.5)
CM147	 	55 × 99 (2.2 × 3.9)	CM022	 	89 × 97 (3.5 × 3.8)
CM442	 	46 × 47 (1.8 × 1.9)	CM362	 	120 × 113 (4.8 × 4.5)
WP201	 	76 × 92 (3.0 × 3.6)	CM286	 	97 × 82 (3.9 × 3.2)
CK970	 	84 × 81 (3.3 × 3.2)	RC765	 	100 × 99 (4.0 × 3.9)



Flowers





























No.	Embroidery motif Colors	Width × height • mm • (in)	No.	Embroidery motif Colors	Width × height • mm • (in)
80001-23	 Orange, Red, Green, Black	85 × 101 (3.4 × 4.0)	BE790404	 Green, Purple, Pink, Blue, Green	202 × 225 (8.0 × 8.9)
12392-1 	 Orange, Purple, Blue, Orange, Light Blue, Pink, Pink	112 × 157 (4.4 × 6.2)	12392-13	 Light Blue, Orange, Orange	112 × 203 (4.4 × 8.0)
12457-13	 Green, Green, Purple, Yellow, Green, Green	113 × 130 (4.5 × 5.1)	12457-06	 Purple, Yellow, Blue, Pink, Pink	106 × 172 (4.2 × 6.8)
BE790401	 Red	205 × 242 (8.1 × 9.5)	BE790405	 Dark Blue	125 × 185 (5.0 × 7.3)
FS142	 Blue, Black	69 × 143 (2.7 × 5.7)	82004-34 	 Green, Pink, Light Green, Yellow, Orange, Red, Red, Pink, Light Blue, Light Green, Yellow, Pink, White, Light Blue, Green	198 × 281 (7.8 × 11.1)
BE790409	 Light Blue, Yellow, Green, Blue, Black, Orange	188 × 215 (7.4 × 8.5)	BE790402	 Brown	146 × 280 (5.8 × 11.0)







No.	Embroidery motif Colors	Width × height • mm • (in)	No.	Embroidery motif Colors	Width × height • mm • (in)
FQ061		75 × 92 (3.0 × 3.7)	FQ801		46 × 112 (1.8 × 4.4)
FQ273		88 × 193 (3.5 × 7.6)	FQ055		84 × 100 (3.3 × 4.0)
FQ982		150 × 218 (5.9 × 8.6)	FB268		123 × 87 (4.9 × 3.4)
FQ934		119 × 192 (4.7 × 7.6)	CM418		45 × 87 (1.8 × 3.4)
FQ972		111 × 73 (4.4 × 2.9)	FQ548		93 × 159 (3.7 × 6.3)
NB513		103 × 111 (4.1 × 4.4)	FQ274		63 × 77 (2.5 × 3.1)

No.	Embroidery motif Colors	Width × height • mm • (in)	No.	Embroidery motif Colors	Width × height • mm • (in)
NB668	 ■ ■ ■ ■	114 × 165 (4.5 × 6.5)	FQ331	 ■ ■ ■ ■ ■ ■	84 × 63 (3.3 × 2.5)
FQ738	 ■ ■ ■ ■ ■	51 × 101 (2.0 × 4.0)	FQ434	 ■ ■ ■ ■	100 × 162 (3.9 × 6.4)
FB419	 ■ ■ ■ ■	64 × 56 (2.5 × 2.2)	WS673	 ■ ■ ■ ■	67 × 170 (2.7 × 6.7)
FQ108	 ■ ■ ■ ■ ■	119 × 136 (4.7 × 5.4)	FQ161	 ■ ■ ■ ■ ■	128 × 170 (5.1 × 6.7)
NB442	 ■ ■ ■ ■ ■	55 × 58 (2.2 × 2.3)	FA971	 ■ ■ ■ ■ ■	115 × 106 (4.5 × 4.2)





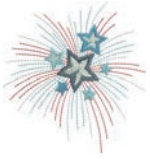





Seasons



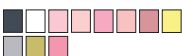



No.	Embroidery motif Colors	Width × height • mm • (in)	No.	Embroidery motif Colors	Width × height • mm • (in)
12384-02	 ■ ■ ■ ■ ■ ■ ■ ■ ■ ■	132 × 203 (5.2 × 8.0)	12384-11	 ■ ■ ■ ■ ■ ■ ■ ■ ■ ■	84 × 189 (3.3 × 7.5)

No.	Embroidery motif Colors	Width × height • mm • (in)	No.	Embroidery motif Colors	Width × height • mm • (in)
12443-03	 	120 × 161 (4.7 × 6.4)	12443-11	 	73 × 193 (2.9 × 7.6)
12427-01	 	133 × 167 (5.3 × 6.6)	12427-11	 	81 × 126 (3.2 × 5.0)
12400-03	 	123 × 161 (4.9 × 6.4)	12400-11	 	74 × 212 (2.9 × 8.3)
HG319	 	88 × 151 (3.5 × 6.0)	HG301	 	124 × 122 (4.9 × 4.8)
BD603	 	80 × 78 (3.2 × 3.1)	HE919	 	89 × 69 (3.5 × 2.7)
HG053	 	122 × 121 (4.8 × 4.8)	NB317	 	87 × 87 (3.4 × 3.4)
NB769	 	128 × 124 (5.1 × 4.9)	NA146	 	63 × 69 (2.5 × 2.7)



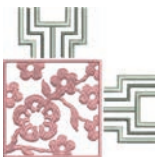

No.	Embroidery motif Colors	Width × height • mm • (in)	No.	Embroidery motif Colors	Width × height • mm • (in)
NB039	 	97 × 127 (3.8 × 5.0)	FQ749	 	77 × 94 (3.1 × 3.7)
HG460	 	91 × 98 (3.6 × 3.9)			

Asia



























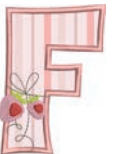





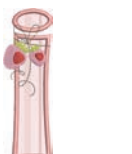

No.	Embroidery motif Colors	Width × height • mm • (in)	No.	Embroidery motif Colors	Width × height • mm • (in)
NB124	 	172 × 132 (6.8 × 5.2)	FQ212	 	61 × 62 (2.4 × 2.4)
FB492	 	86 × 293 (3.4 × 11.5)	FQ194	 	120 × 118 (4.7 × 4.7)
FQ217	 	84 × 59 (3.2 × 2.3)	FA427	 	111 × 66 (4.4 × 2.6)















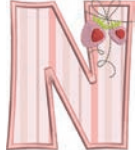

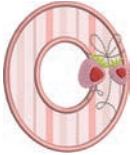













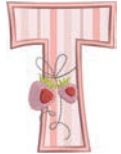









No.	Embroidery motif Colors	Width × height • mm • (in)	No.	Embroidery motif Colors	Width × height • mm • (in)
FB276	 ■ ■	124 × 112 (4.9 × 4.4)	FB283	 ■ ■	102 × 109 (4.0 × 4.3)
FB490	 ■ ■ ■	67 × 67 (2.7 × 2.7)	FB491	 ■ ■ ■	31 × 165 (1.3 × 6.5)
NB491	 ■	79 × 168 (3.1 × 6.6)	FB484	 ■	66 × 59 (2.6 × 2.3)

Sport





































No.	Embroidery motif Colors	Width × height • mm • (in)	No.	Embroidery motif Colors	Width × height • mm • (in)
BE790601	 ■ ■	80 × 80 (3.2 × 3.2)	BE790602	 ■ ■ ■	80 × 75 (3.2 × 3.0)
BE790603	 ■ ■	80 × 74 (3.2 × 2.9)	BE790604	 ■ ■ ■ ■	79 × 80 (3.1 × 3.2)
BE790605	 ■ ■ ■ ■	79 × 79 (3.1 × 3.1)	BE790606	 ■ ■	100 × 86 (3.9 × 3.4)





































Monograms in pink







No.	Embroidery motif Colors	Width × height • mm • (in)	No.	Embroidery motif Colors	Width × height • mm • (in)
BE790101 	 	75 × 89 (3.0 × 3.5)	BE790102 	 	73 × 89 (2.9 × 3.5)
BE790103 	 	64 × 92 (2.5 × 3.7)	BE790104 	 	90 × 97 (3.6 × 3.8)
BE790105 	 	61 × 89 (2.4 × 3.5)	BE790106 	 	63 × 90 (2.5 × 3.5)
BE790107 	 	79 × 90 (3.1 × 3.5)	BE790108 	 	70 × 90 (2.8 × 3.5)
BE790109 	 	32 × 100 (1.3 × 4.0)	BE790110 	 	73 × 89 (2.9 × 3.5)
BE790111 	 	65 × 89 (2.6 × 3.5)	BE790112 	 	70 × 89 (2.8 × 3.5)

No.	Embroidery motif Colors	Width × height • mm • (in)	No.	Embroidery motif Colors	Width × height • mm • (in)
BE790113 	 	88 × 90 (3.5 × 3.6)	BE790114 	 	76 × 90 (3.0 × 3.6)
BE790115 	 	74 × 89 (2.9 × 3.5)	BE790116 	 	71 × 103 (2.8 × 4.1)
BE790117 	 	82 × 100 (3.2 × 4.0)	BE790118 	 	73 × 103 (2.9 × 4.1)
BE790119 	 	60 × 89 (2.4 × 3.5)	BE790120 	 	71 × 99 (2.8 × 3.9)
BE790121 	 	77 × 89 (3.1 × 3.5)	BE790122 	 	86 × 89 (3.4 × 3.5)
BE790123 	 	104 × 89 (4.1 × 3.5)	BE790124 	 	90 × 92 (3.6 × 3.6)
BE790125 	 	84 × 89 (3.3 × 3.5)	BE790126 	 	56 × 89 (2.2 × 3.5)

















Monograms in blue





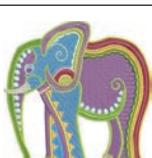

No.	Embroidery Design Colors	Width × height • mm • (in)	No.	Embroidery Design Colors	Width × height • mm • (in)
BE790201 	 	85 × 95 (3.3 × 3.8)	BE790202 	 	79 × 95 (3.1 × 3.8)
BE790203 	 	78 × 95 (3.1 × 3.8)	BE790204 	 	104 × 96 (4.1 × 3.8)
BE790205 	 	83 × 95 (3.3 × 3.8)	BE790206 	 	77 × 96 (3.1 × 3.8)
BE790207 	 	92 × 95 (3.7 × 3.8)	BE790208 	 	87 × 95 (3.5 × 3.8)
BE790209 	 	51 × 111 (2.0 × 4.4)	BE790210 	 	88 × 95 (3.5 × 3.8)
BE790211 	 	75 × 95 (3.0 × 3.8)	BE790212 	 	83 × 95 (3.3 × 3.8)

No.	Embroidery Design Colors	Width × height • mm • (in)	No.	Embroidery Design Colors	Width × height • mm • (in)
BE790213 	 	99 × 101 (3.9 × 4.0)	BE790214 	 	89 × 94 (3.5 × 3.7)
BE790215 	 	88 × 95 (3.5 × 3.8)	BE790216 	 	71 × 95 (2.8 × 3.7)
BE790217 	 	86 × 102 (3.4 × 4.0)	BE790218 	 	82 × 95 (3.3 × 3.7)
BE790219 	 	79 × 95 (3.1 × 3.8)	BE790220 	 	69 × 95 (2.7 × 3.8)
BE790221 	 	90 × 95 (3.5 × 3.8)	BE790222 	 	93 × 95 (3.7 × 3.8)
BE790223 	 	114 × 95 (4.5 × 3.8)	BE790224 	 	93 × 95 (3.7 × 3.8)









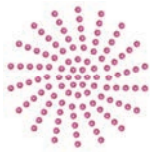

No.	Embroidery Design Colors	Width × height • mm • (in)	No.	Embroidery Design Colors	Width × height • mm • (in)
BE790225 	 	89 × 95 (3.5 × 3.8)	BE790226 	 	59 × 96 (2.3 × 3.8)

















Animals

No.	Embroidery motif Colors	Width × height • mm • (in)	No.	Embroidery motif Colors	Width × height • mm • (in)
CM140	 	88 × 97 (3.5 × 3.9)	CM142	 	56 × 66 (2.2 × 2.6)
FB258	 	83 × 184 (3.3 × 7.2)	FQ106	 	109 × 109 (4.3 × 4.3)
FQ617	 	118 × 198 (4.6 × 7.8)	FQ624	 	64 × 144 (2.5 × 5.7)
MT022	 	123 × 125 (4.9 × 4.9)	MT028	 	103 × 93 (4.1 × 3.7)

No.	Embroidery motif Colors	Width × height • mm • (in)	No.	Embroidery motif Colors	Width × height • mm • (in)
WM785	 ■	84 × 103 (3.3 × 4.1)	WP217	 	93 × 78 (3.7 × 3.1)
WP244	 	136 × 172 (5.4 × 6.8)	WS610	 ■	127 × 111 (5.0 × 4.4)











DesignWorks

No.	Embroidery Design Colors	Width × height • mm • (in)	No.	Embroidery Design Colors	Width × height • mm • (in)
DW11 		70 × 71 (2.8 × 2.8)	BE790901 		252 × 181 (9.9 × 7.9)
BE790903 		181 × 292 (7.1 × 11.5)	BE790905 		104 × 227 (4.1 × 8.9)
BE790906 		192 × 195 (7.6 × 7.7)	BE790909 		167 × 322 (6.6 × 12.7)

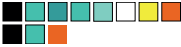











No.	Embroidery Design Colors	Width × height • mm • (in)	No.	Embroidery Design Colors	Width × height • mm • (in)
DW07 		114 × 152 (4.5 × 6.0)	DW05 		105 × 94 (4.2 × 3.7)
DW10 		184 × 184 (7.3 × 7.3)	DW08 		206 × 100 (8.1 × 4.0)
BE700121 		196 × 197 (7.8 × 7.8)	BE700122 		119 × 37 (4.7 × 1.5)
BE700123 		112 × 205 (4.4 × 8.1)	BE700124 		141 × 134 (5.6 × 5.3)















Projects











You can find the detailed embroidery instructions at www.bernina.com/7seriesdesigns.

No.	Embroidery Design Colors	Width × height • mm • (in)	No.	Embroidery Design Colors	Width × height • mm • (in)
BE700701 	 	208 × 201 (8.2 × 7.9)	12604-02 	 	45 × 152 (1.8 × 6.0)
21519-03 	 	108 × 161 (4.3 × 6.4)	19999-03 2 	 	90 × 143 (3.6 × 5.6)





Charming Monograms

























No.	Embroidery motif Colors	Width × height • mm • (in)	No.	Embroidery motif Colors	Width × height • mm • (in)
12587-01	 □	58 × 89 (2.3 × 3.5)	12587-02	 □	52 × 89 (2.1 × 3.5)
12587-03	 □	45 × 89 (1.8 × 3.5)	12587-04	 □	56 × 90 (2.2 × 3.6)
12587-05	 □	50 × 90 (2.0 × 3.6)	12587-06	 □	57 × 89 (2.2 × 3.5)
12587-07	 □	39 × 90 (1.5 × 3.6)	12587-08	 □	62 × 90 (2.4 × 3.6)
12587-09	 □	49 × 89 (1.9 × 3.5)	12587-10	 □	57 × 89 (2.2 × 3.5)
12587-11	 □	61 × 90 (2.4 × 3.6)	12587-12	 □	63 × 90 (2.5 × 3.5)

No.	Embroidery motif Colors	Width × height • mm • (in)	No.	Embroidery motif Colors	Width × height • mm • (in)
12587-13	 □	64 × 92 (2.5 × 3.6)	12587-14	 □	63 × 90 (2.5 × 3.6)
12587-15	 □	44 × 90 (1.8 × 3.6)	12587-16	 □	63 × 89 (2.5 × 3.5)
12587-17	 □	54 × 89 (2.1 × 3.5)	12587-18	 □	64 × 90 (2.5 × 3.6)
12587-19	 □	56 × 90 (2.2 × 3.6)	12587-20	 □	57 × 89 (2.2 × 3.5)
12587-21	 □	62 × 91 (2.4 × 3.6)	12587-22	 □	64 × 91 (2.5 × 3.6)
12587-23	 □	64 × 90 (2.5 × 3.6)	12587-24	 □	62 × 90 (2.5 × 3.6)
12587-25	 □	51 × 91 (2.5 × 3.6)	12587-26	 □	67 × 89 (2.7 × 3.5)

No.	Embroidery motif Colors	Width × height • mm • (in)	No.	Embroidery motif Colors	Width × height • mm • (in)
12587-53	 □	67 × 22 (2.7 × 0.9)	12587-54	 □	50 × 106 (2.0 × 4.2)
12587-55	 □	70 × 144 (2.8 × 5.7)	12587-56	 □	49 × 100 (1.9 × 3.9)
12587-57	 □	57 × 20 (2.3 × 0.8)	12587-58	 □	52 × 116 (2.1 × 4.6)
12587-59	 □	33 × 94 (1.3 × 3.7)	12587-60	 □	126 × 126 (5.0 × 5.0)
12587-61	 □	35 × 28 (1.4 × 1.1)	12587-62	 □	35 × 33 (1.4 × 1.3)

Homedeco

No.	Embroidery motif Colors	Width × height • mm • (in)	No.	Embroidery motif Colors	Width × height • mm • (in)
12535-03	  □	160 × 120 (6.3 × 4.7)	82011-30	  □	107 × 130 (4.2 × 5.1)

No.	Embroidery motif Colors	Width × height • mm • (in)	No.	Embroidery motif Colors	Width × height • mm • (in)
82011-28	 	133 × 99 (5.3 × 3.9)	82006-02	 	128 × 205 (5.1 × 8.1)
WP428	 	132 × 119 (5.2 × 4.7)	12576-05	 	189 × 229 (7.5 × 9.0)
12473-04	 	93 × 184 (3.7 × 7.3)	12620-12	 	94 × 109 (3.7 × 4.3)
12611-08 	 	80 × 119 (3.2 × 4.7)	12611-18	 	130 × 157 (5.1 × 6.2)
BE790801	 	137 × 137 (5.4 × 5.4)	BE790802	 	36 × 117 (1.4 × 4.6)
BE790803	 	36 × 351 (1.4 × 13.8)	WP423	 	90 × 158 (3.6 × 6.2)

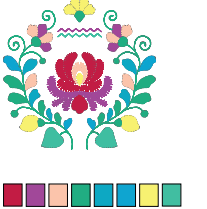
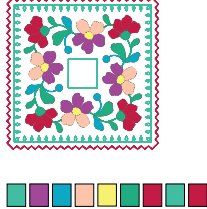
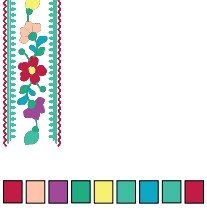
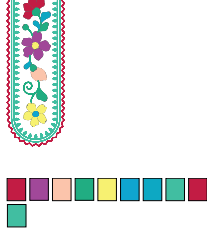
No.	Embroidery motif Colors	Width × height • mm • (in)	No.	Embroidery motif Colors	Width × height • mm • (in)
21027-01		123 × 122 (4.8 × 4.8)	21027-14		120 × 120 (4.8 × 4.8)
21027-16		57 × 152 (2.3 × 6.0)	21027-17		57 × 151 (2.3 × 6.0)

Index

A

Activate/Deactivate Functions.....	25
Adjust Values.....	25
Adjusting the Presser Foot Position via the Knee Lifter of the Free Hand System.....	37
Adjusting the Thread Cut.....	54
Adjusting the Upper Thread Tension.....	49
Alphabets.....	105
Altering size of monogram.....	106
Altering the Embroidery Design Size Disproportionally.....	145
Altering the Embroidery Design Size Proportionally.....	145
Altering the Stitch Density.....	146
Attaching the Hoop.....	138
Attaching the Knee Lifter of the Free Hand System.....	33
Attaching the Module.....	131

B

BERNINA Dual Feed.....	62
Activating/Deactivating.....	63
Buttonholes.....	107

C

Calibrating the Buttonhole Foot with Slide #3A.....	59
Calibrating the Display.....	57
Calibrating the Embroidery Hoop.....	53
Calling up the Creative Consultant.....	61
Calling up the Embroidery Consultant.....	61
Calling Up the Help.....	61
Calling up the Tutorial.....	61
Changing the Needle.....	38
Changing the Presser Foot.....	37
Changing the Stitch Plate.....	40
Checking the firmware version.....	168
Child safety lock.....	61
Cleaning the Feed Dog.....	169
Cleaning the Hook.....	170
Combination Mode.....	67, 153
Combining Embroidery Designs.....	153
Cord.....	110
Creating Lettering.....	156

D

Decorative Stitches.....	97
Dispose of the Machine.....	181

E

Editing the Lettering.....	156
Embroidery file format.....	128
Embroidery Test.....	129
Energy-saving Mode.....	61
Entering dealer data.....	60
Environmental Protection.....	11
Error Messages.....	173
Explanation of Symbols.....	12

F

Firmware	
Activate/Deactivate Functions.....	25
Adjust Values.....	25
Navigation.....	25
Fitting the Embroidery Needle.....	133
Fitting the Stitch Plate.....	134
Foot Control.....	34
Connecting.....	32
Free Point Positioning.....	152

I

Inserting the Spool Cap.....	35
------------------------------	----

L

Lubricating the Hook.....	170
---------------------------	-----

M

Maintenance and Cleaning.....	169
Moving the hoop to the Back.....	139
Moving the Module for the Sewing Mode.....	139

N

Navigation.....	25
Needle Stop Up/Down (Permanent).....	40
Needle Up/Down	
via the Foot Control.....	34
Needle, Thread, Fabric.....	27
Needle/Thread Combination.....	30
Needles Overview.....	27

O

Overview Embroidery Module.....	126
Overview of Embroidery Designs.....	187



BERNINA recommends threads from *Mettler*[®]

BERNINA International AG | CH-8266 Steckborn Switzerland | www.bernina.com | © Copyright by BERNINA International AG

0359645_30A_04
2023-01 EN

made to create **BERNINA**